

# TOSHIBA

Leading Innovation >>>



**SMMS**   
SUPER MODULAR MULTI SYSTEM

Air Conditioning for large buildings

Cooling Only Model For Singapore





## Toshiba solutions

At Toshiba, we believe that "Evolution is leading the path to a better future". Through the decades, we have been constantly creating innovative and high-quality electrical appliances to increase our consumers' satisfaction. Now, with Toshiba "SMMS-e", the latest commercial air conditioning for various buildings,

The SMMS-e has been creatively developed and designed under the concept Excellence, Expansion, and Experience to ensure your utmost comfort and convenience like never before.

With the latest technology improved and developed to make SMMS-e the top commercial air conditioning for any solution that intelligently meets your needs, Toshiba will stop at nothing to create innovation to evolution of the future, where life is a step away from perfection.

## INDEX

<b>Introduction</b>	<b>3</b>
<b>SMMS-e features Energy saving</b>	<b>8</b>
Diversity	10
Prevent small animals	11
Capacity range	12
SMMS wave tool	14
DC twin-rotary compressor	16
Heat exchanger	17
Piping design flexibility	18
Slimmer pipe size	20
Propeller fan	21
Reliability	22
Operating temperature range	23
<b>Outdoor units</b>	
Outdoor units line-up	24
Outdoor units specifications	26
Outdoor units external view drawings	34
<b>Indoor units</b>	
Indoor units line-up for SMMS-e	38
4-way Air Discharge Cassette type	40
Compact 4-way Cassette (600 x 600) Type	42
2-way Air Discharge Cassette Type	44
1-way Air Discharge Cassette Type	46
Slim Duct Type	48
Concealed Duct High Static Pressure Type	50
Concealed Duct Type	52
Ceiling Type	54
High-wall Type (3 series)	56
Console Type	57
Floor Standing Cabinet Type	58
Floor Standing Concealed Type	59
Floor Standing Type	60
Large capacity Floor Standing Type	61
Fresh Air Intake Indoor Unit Type	62
Air-to-Air Heat Exchanger with DX-coil	64
Air-to-Air Heat Exchanger	66
Indoor unit accessories for SMMS-e	68
<b>Remote controllers</b>	<b>70</b>
<b>Building management systems</b>	<b>74</b>
<b>Open network systems</b>	<b>76</b>
<b>Application controls</b>	<b>78</b>
<b>Safety precautions</b>	<b>80</b>

**TOSHIBA**  
Leading Innovation >>>

**SMMS**  
SUPER MODULAR MULTI SYSTEM



Air Conditioning for large buildings

**EXCELLENCE**

**EXPANSION**

**EXPERIENCE**



# *e*volution

 *XPANSION*



**SMMS**  
SUPER MODULAR MULTI SYSTEM



**Air Conditioning for large buildings**

on

 XPERIENCE



 XCELLENCE



**PRODUCT LINE UP**

**Space saving model**

Equivalent HP	8HP	10HP	12HP	14HP	16HP	18HP	20HP	22HP
Appearance								
External dimensions (H x W x D)	1,800 x 990 x 780mm			1,800 x 1,210 x 780mm			1,800 x 1,600 x 780mm	
Refrigerant type	R410A							
Compressor	DC Twin-Rotary Compressor x 2							

**High efficiency/High diversity model**

Equivalent HP	14HP	18HP
Appearance		
External dimensions (H x W x D)	1,800 x 1,210 x 780mm	1,800 x 1,600 x 780mm
Refrigerant type	R410A	
Compressor	DC Twin-Rotary Compressor x 2	

**Product line up**

	8HP	10HP	12HP	14HP	16HP	18HP	20HP	22HP	24HP	26HP	28HP	30HP	32HP	34HP	36HP	38HP	40HP	42HP	44HP	46HP	48HP	50HP	52HP	54HP	56HP	58HP	60HP	
Space saving model	●	●	●	●	●	●	●	●	●	●	●	●	●	●	●	●	●	●	●	●	●	●	●	●	●	●	●	●
High efficiency /High diversity model	●	●	●	●	●	●	●	●	●	●	●	●	●	●	●	●	●	●	●	●	●	●	●	●	●	●	●	●





**ENERGY SAVING**

**Greater efficiency performance**

Adopting the highly efficient new DC twin-rotary compressors with various technologies.

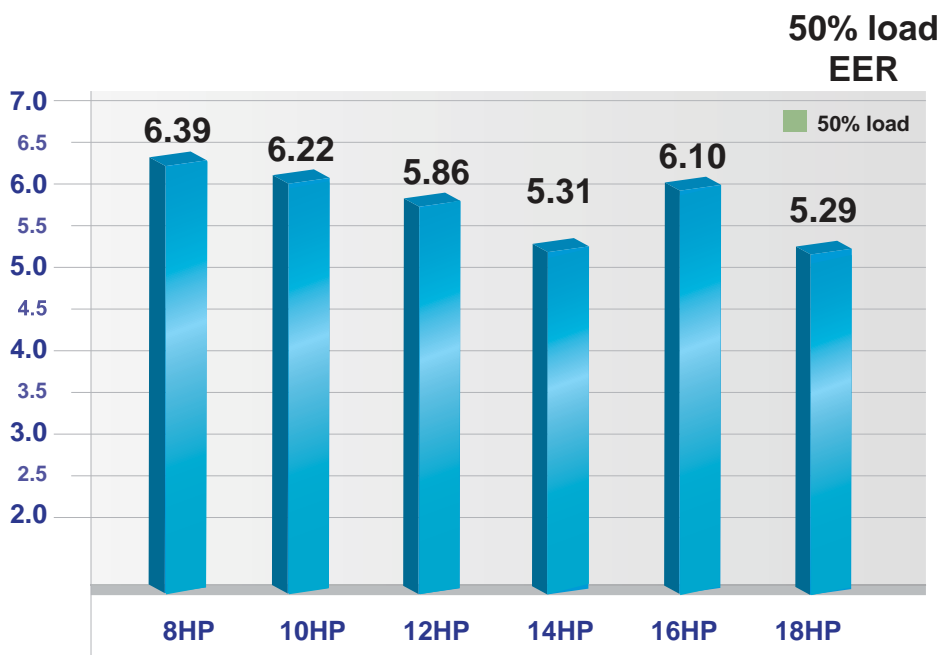

\*Conditions: Cooling: Indoor air temperature 27°C DB/19°C WB, outdoor air temperature 35°C DB

\*High efficiency/High diversity model by single outdoor unit





## DIVERSITY

### Greater diversity

Thanks to the newly developed refrigerant circuit, the diversity of outdoor units has drastically increased. This makes it much easier to design for installations with many rooms or offices.

High efficiency model/High diversity model

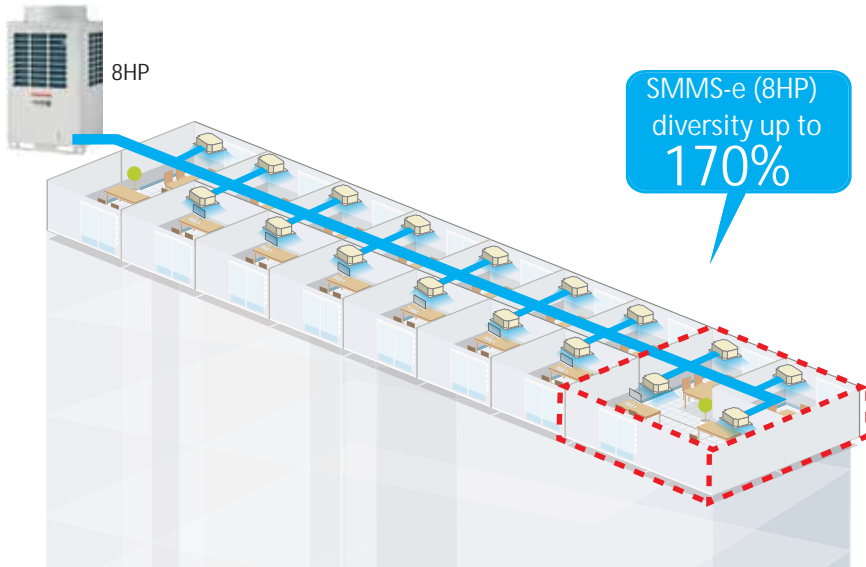

	SMMS-e	Current
8HP	170%	
10HP	150%	
12HP	135%	
14HP	145%	
16HP	135%	
18HP	150%	
20HP	150%	
22HP	140%	
24HP	135%	
26HP	140%	
28HP	145%	
30HP	140%	
32HP	135%	
34HP	140%	
36HP	135%	
38HP	140%	
40HP	140%	
42HP	145%	
44HP	140%	
46HP	140%	
48HP	135%	
50HP	140%	
52HP	135%	
54HP	145%	
56HP	140%	
58HP	135%	
60HP	135%	
		135%



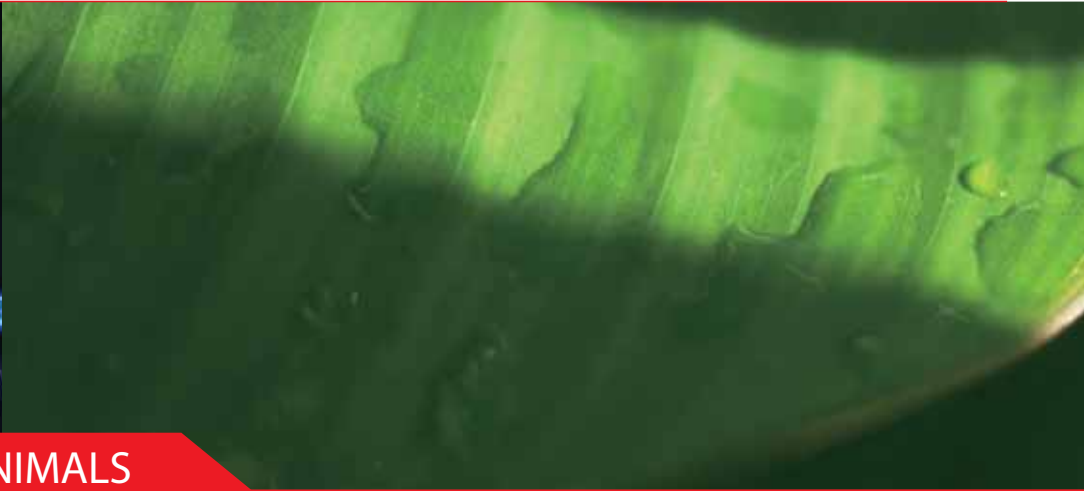

## PREVENT SMALL ANIMALS

### Prevent small animals getting into the inverter

To prevent the small animals from entering and interfering with the electronic components in the system, our new inverter box has been upgraded with additional protection, while allowing reliable operation. The inverter box is fitted with punched sheet metal & resin sheet.



**1** Seal wiring holes with resin sheet

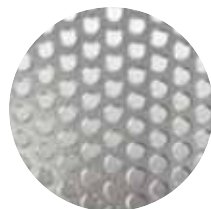

**2** The diameter of each punched sheet metal is  $\phi 4\text{mm}$

\*This is applicable for small animals bigger than 4mm.





## CAPACITY RANGE

### Single unit capacity expanded

SMMS-e comes with 3 new larger capacity units, producing up to 22HP on a single module platform.



### Industry-leading installation flexibility

Outdoor units improve performance to achieve greater space efficiency that defies their compact module size to deliver greater freedom in layout design. This minimizes weight-related restrictions and allows for quicker installation.

\*Space saving model

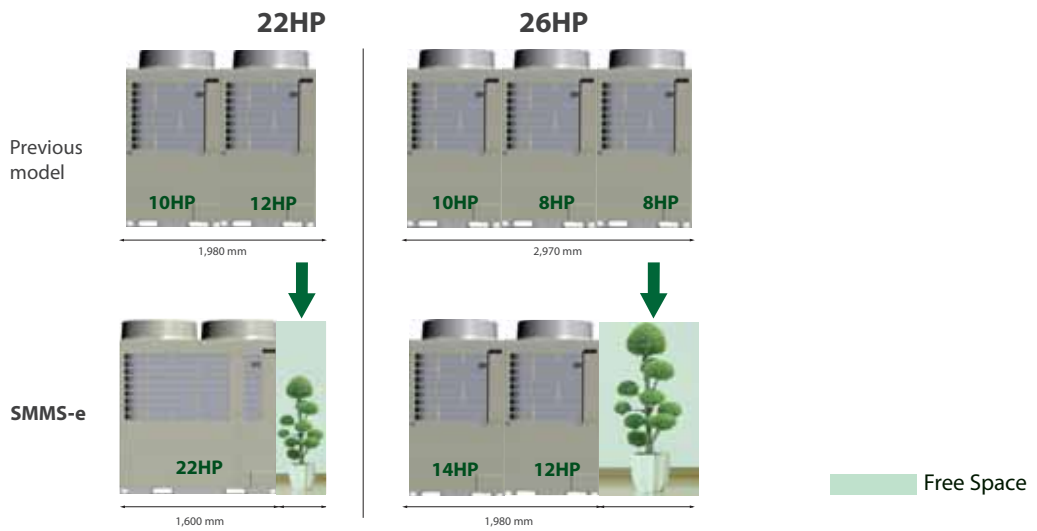



## System capacity expanded

With the SMMS-e, it is now possible to connect up to 60HP in one system, with up to 64 connectable indoor units.

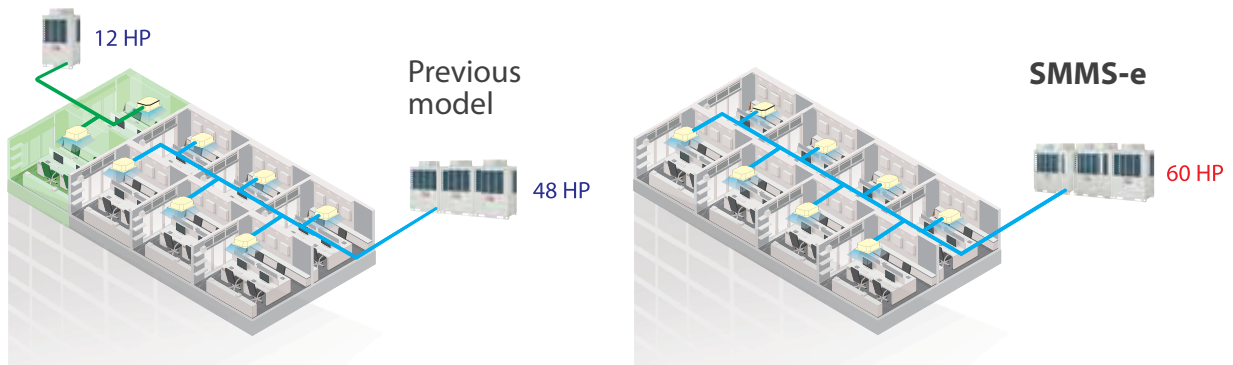

## Installation flexibility

While expanding the maximum combination from 48 to 60HP in one system. This helps save more time and expense on additional unit system required in the previous model. The new compact unit design also increases more flexibility on installation with less foot print.

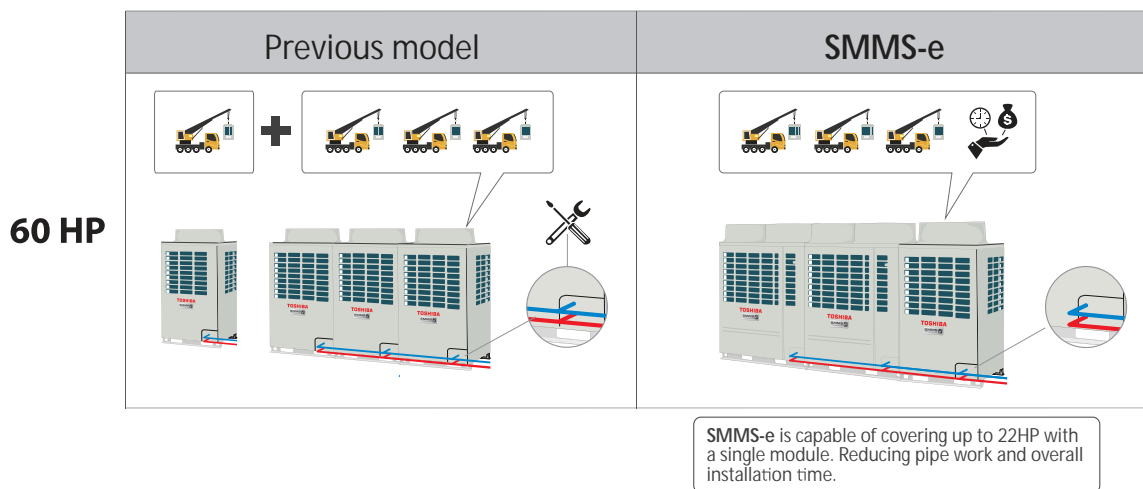



### SMMS wave tool

With SMMS wave Tool, you can read and write data from outdoor unit directly on your smart phone without the needs of connecting PC or opening cabinet.

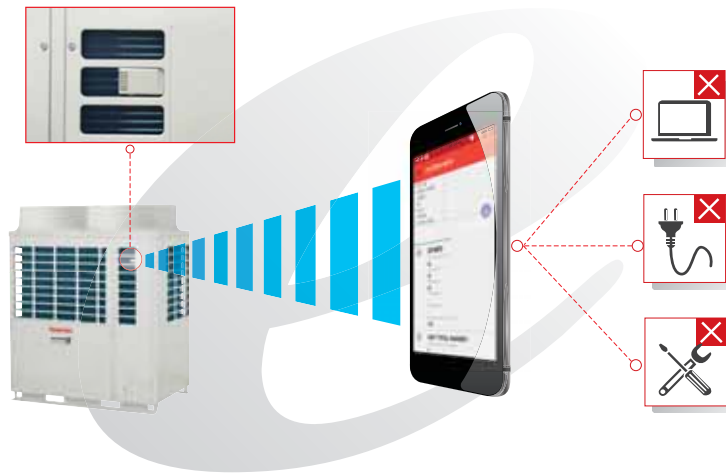

By the new smart phone application, the testing and commissioning can be done without opening the cabinet.

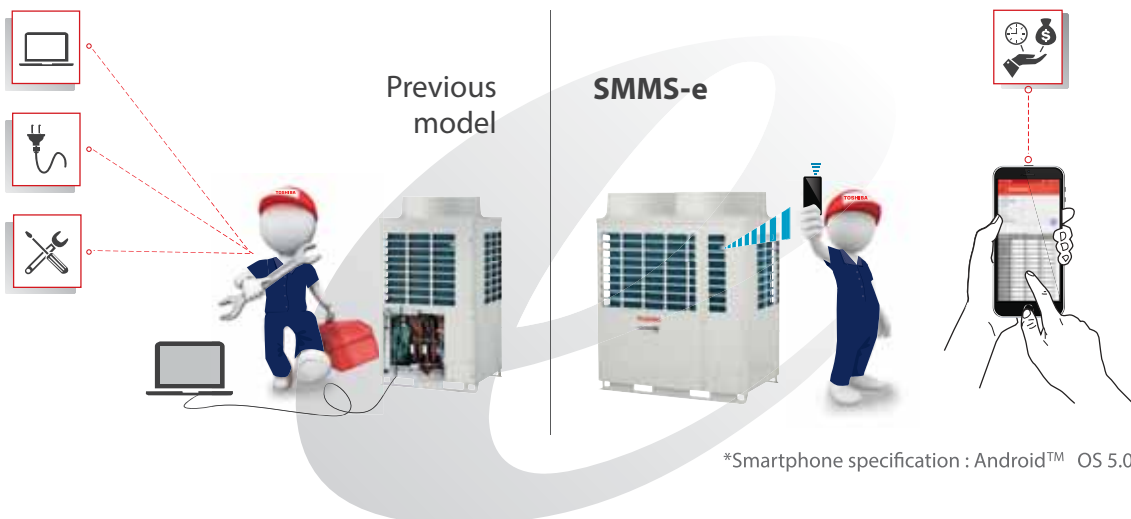

## Available data

Whether the product data, system data, fault history or testing and commissioning, all can be obtained easily even in case of under service maintenance or power failure. The data can be easily sent to the distant office via email. Possible to receive system data by e-mail without moving from your office and the operation conditions can be checked in the office.

In case of below situation

- ✓ Installation
- ✓ Service maintenance
- ✓ Power failure

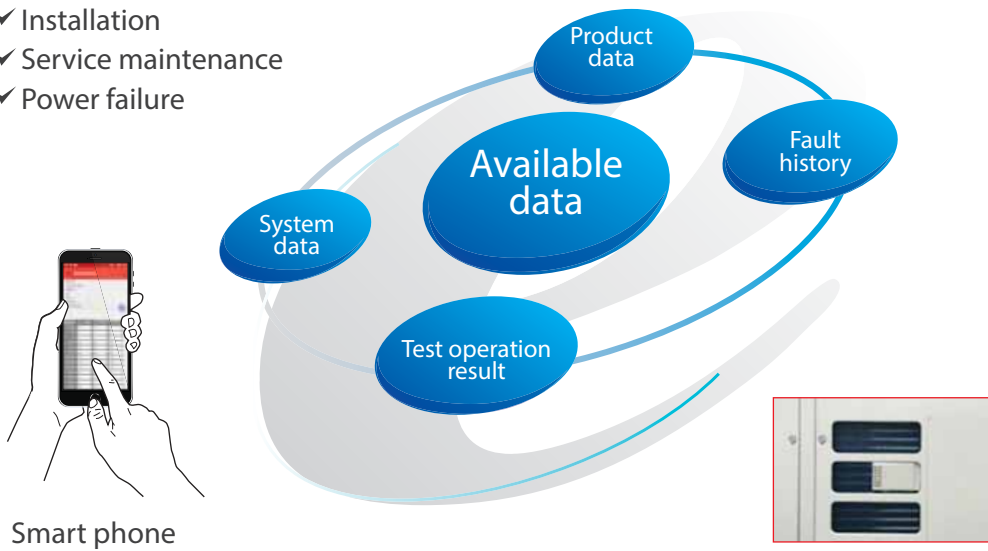

Smart phone



The Site

The office





## DC TWIN-ROTARY COMPRESSOR

### Wide range compressor

More powerful and efficient with the cutting-edge technology of compressor – DC Twin-Rotary operates in wider range of rotation speed.

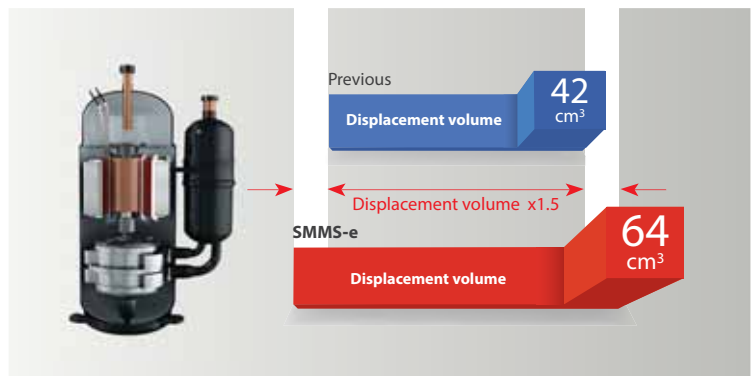

### DLC coated vane

Increased hardness of the DLC coated vane reduces friction and increase both reliability and performance.

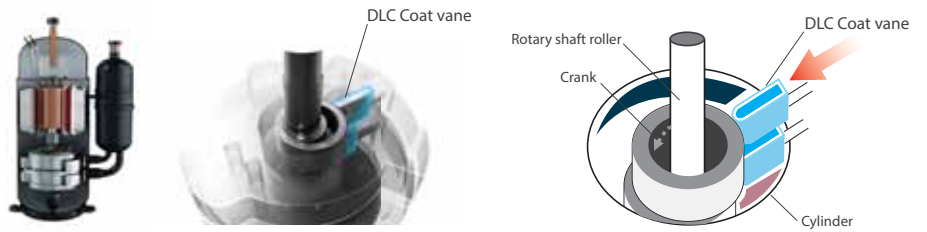

\* DLC: Diamond Like Carbon

### 2-stage vane

With 2-stage vane innovatively designed to reduce friction while increasing hardness and enhancing performance at its best.

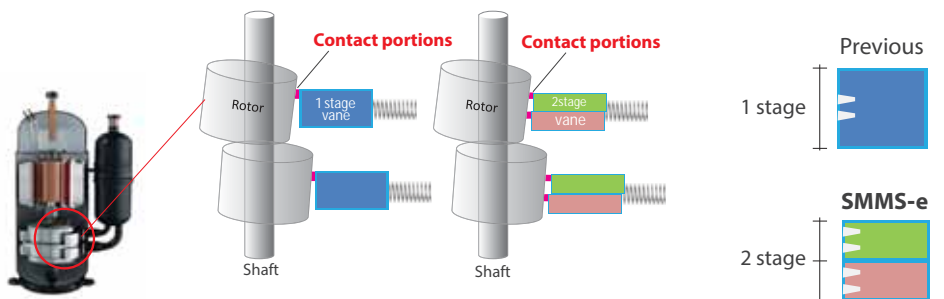



## HEAT EXCHANGER

### New heat exchanger

New heat exchanger of SMMS-e increases from 2 to 3 rows, providing even more surface area of the total pipe up to 13%.

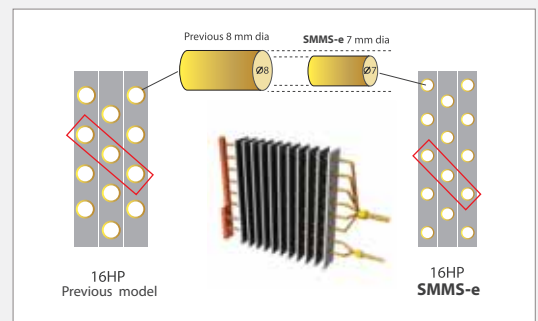
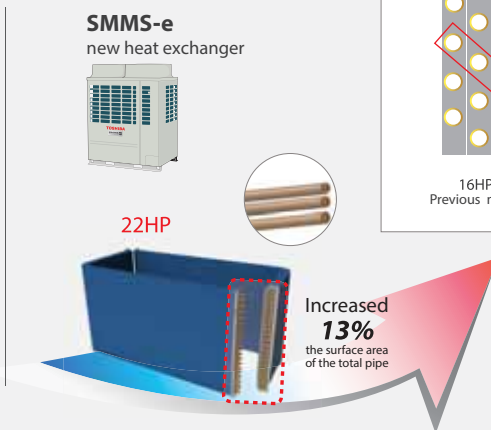
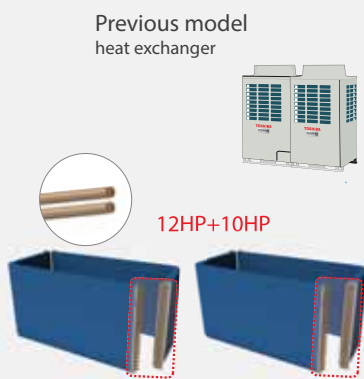

### Variable heat exchanger

New system controls allows the outdoor unit to select the most efficient heat exchanger size, which matches the capacity load in order to provide higher energy savings.

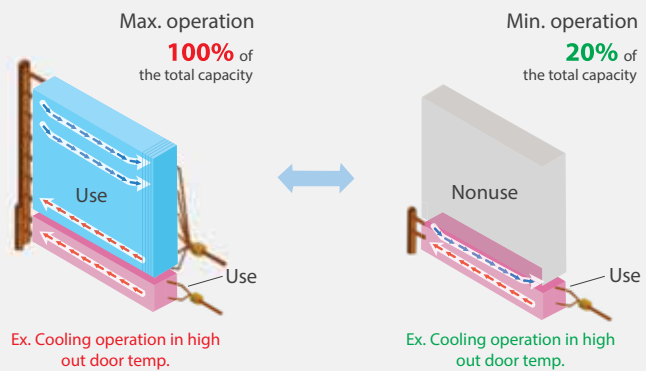

### 4-way heat exchanger can realize balanced airflow

Heat exchangers are located on all four sides of the outdoor unit, ensuring air flow is equal in all directions.

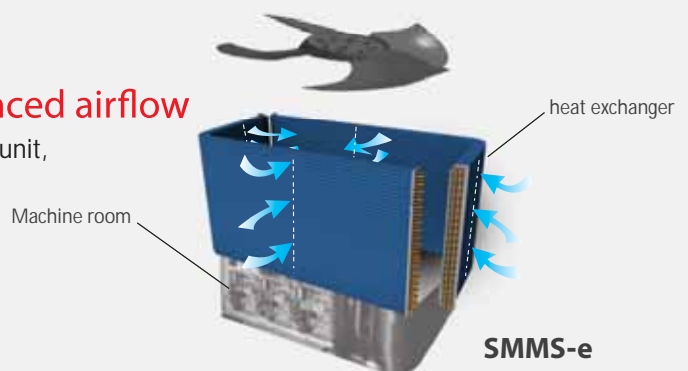



## PIPING DESIGN FLEXIBILITY

### Total piping length

Applied with Toshiba's unique and greatly improved technology, SMMS-e can reach up to 1,000 meters maximum piping length.

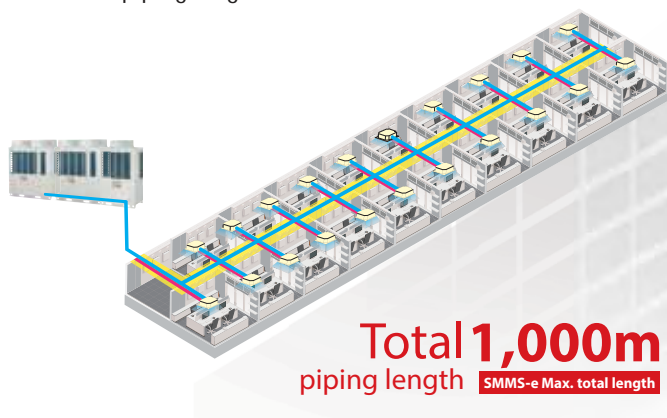

### Farthest pipe from 1st branch

Even more convenient with the piping distance from the first branch to the furthest indoor unit at 90 meters, increasing the flexibility of the installation within the hotel or office building.

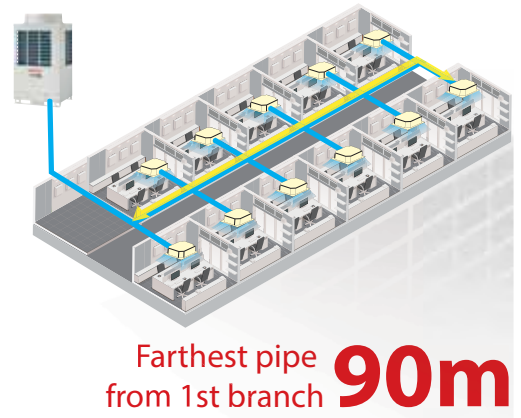

### Farthest equivalent length

The maximum equivalent distance between outdoor unit and farthest indoor unit tops at 235 meters, which tops the industry class.

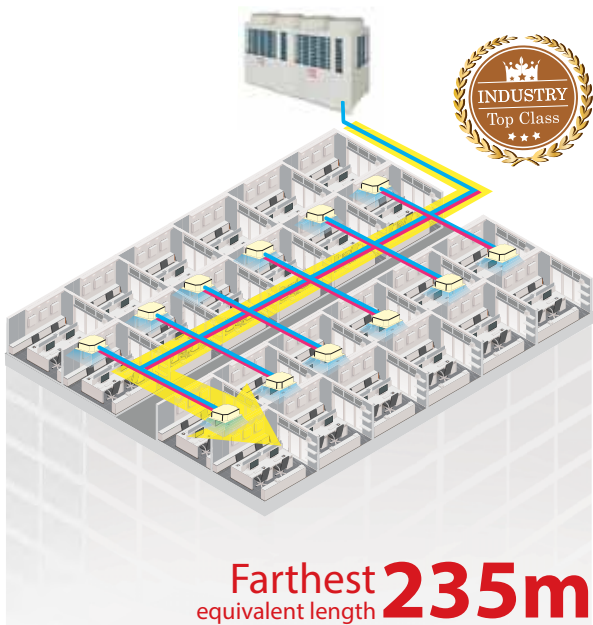

### Height between indoor units

Another industry's top class is a maximum vertical distance between indoor units which reaches up to 40 meters, equal to an entire 11-storied building. SMMS-e's enhanced piping capabilities result in more benefits for the system design, installation flexibility, as well as the less installation cost.



## Piping capabilities summary

Piping capability can provide more benefits for the system design, the installation flexibility, and the installation cost.

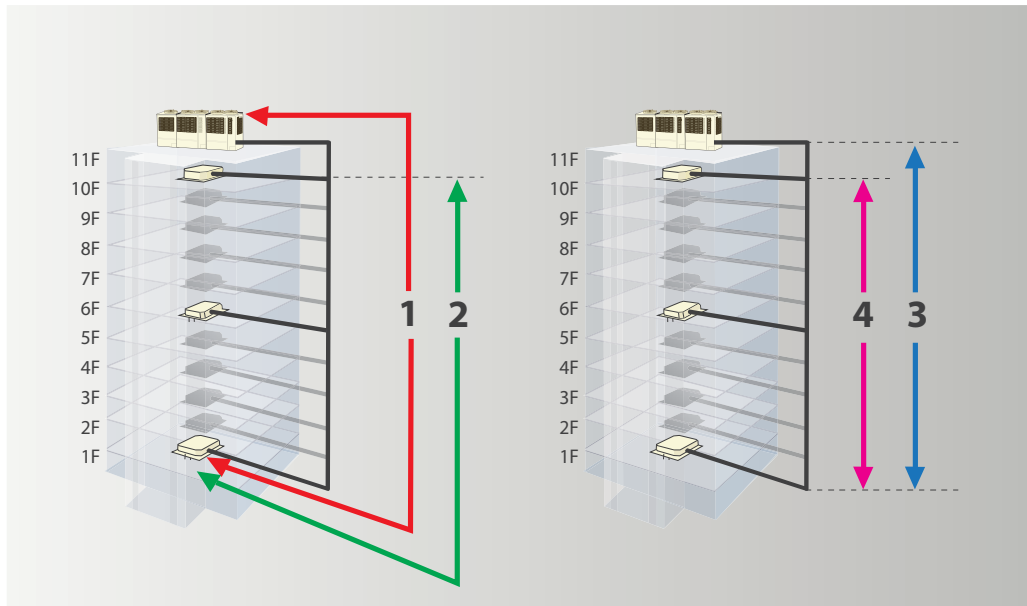

<b>Total length</b>	1,000m*
1. Farthest equivalent length	235m
2. Farthest pipe from 1 <sup>st</sup> branch	90m**
3. Height between outdoor unit - indoor unit ( outdoor unit above/below )	90m*** / 40m
4. Height between indoor unit - indoor unit	40m

\* : 34HP combination or more

\*\* : 65m if the height piping length between outdoor unit and indoor unit is more than 3m

\*\*\* : Be sure to refer to the Engineering Data Book for details of these conditions and requirements.





## SLIMMER PIPE SIZE

### Piping saving costs

With the sub-cool heat exchanger less refrigerant is needed therefore now it is possible to use smaller pipes and save in installation costs.

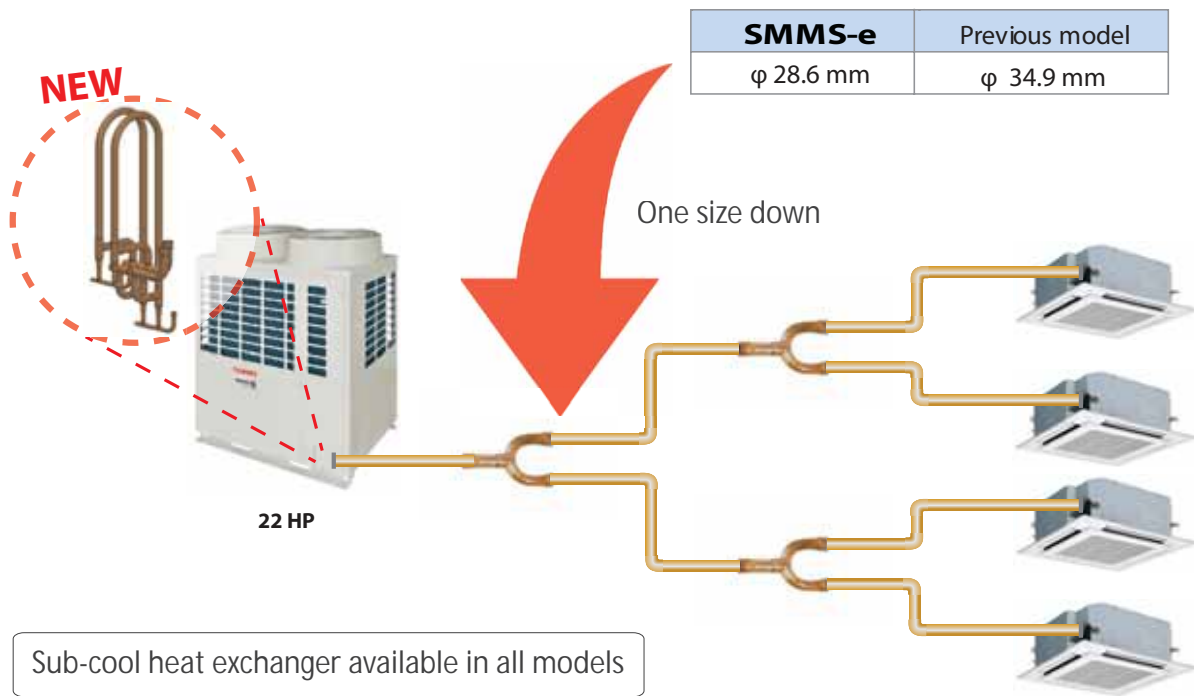





**PROPELLER FAN**

**New advanced blade shapes for a better air flow management**

Every single blade is designed with a unique profile, a solution that guarantees a smoother air flow without turbulences. The new propeller deliver the same amount of air with less sound pressure level.



Each blade has a unique profile	Design improvements
<p>A B</p>  <p>C D</p>	<p>New anti-eddy projections on the back of the fan</p>  <p>New profiles of the reverse-arc shaped wings</p>

**More quiet in comparison with the previous fan**

In the same working condition the new design of the propeller ensure a reduction of 1.5 dB compared to the previous models

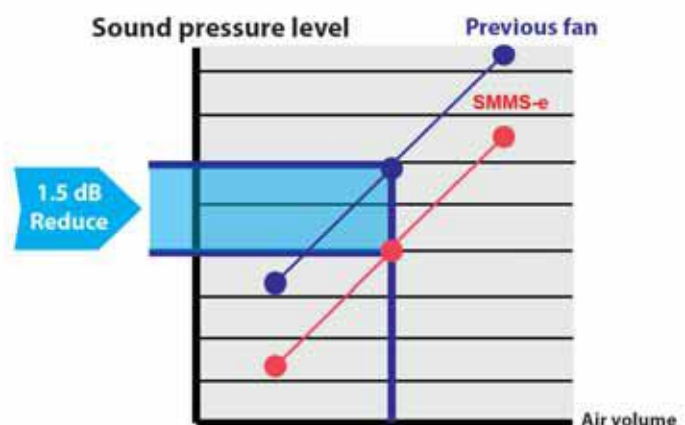



**RELIABILITY**

**Backup operation**

In case of a compressor failure, SMMS-e can keep working with the backup operation under All Inverter Control to compensate a failed compressor or header unit. This backup operation is available in both a single system or as a module.

**Single outdoor unit backup**

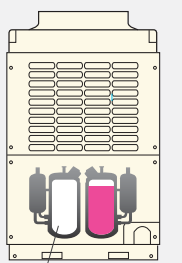

Failed compressor

**Module outdoor unit backup**

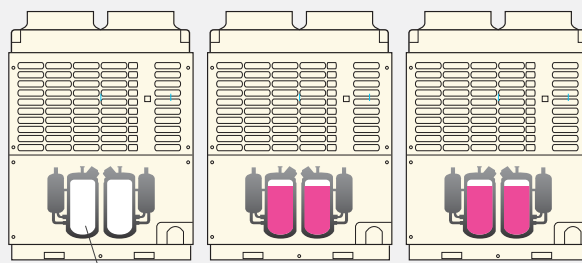

Failed outdoor unit

**Reliability rotational control**

The rotational control in SMMS-e is designed to improve system reliability by controlling the operation of each compressor to work equally under variable conditions.

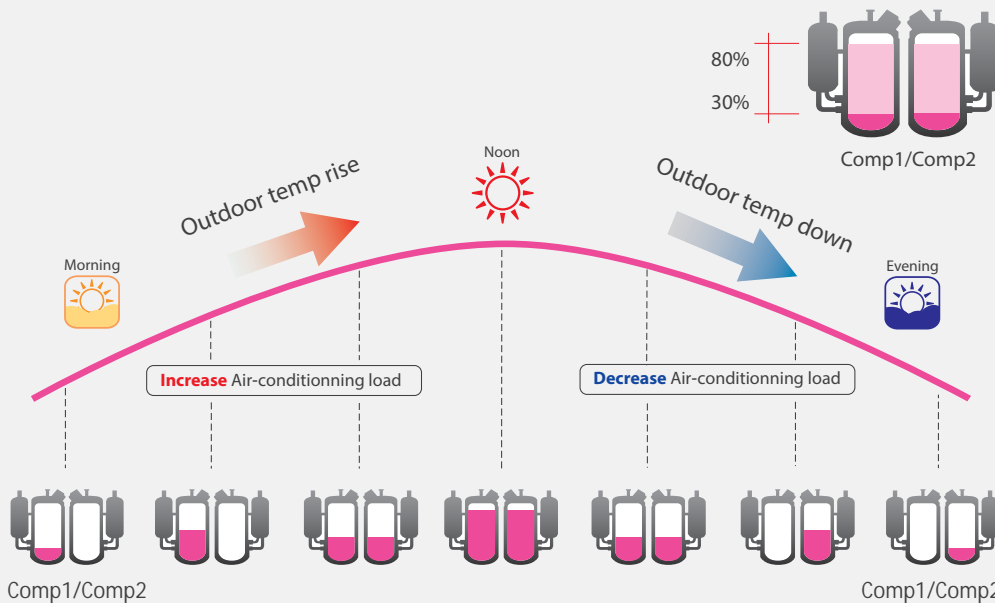



## OPERATING TEMPERATURE RANGE

### Outdoor temperature range

Utilizing the newly designed compressor, SMMS-e can operate under the wider range of outdoor ambience with the expansion of cooling from  $-5^{\circ}\text{C}$  to  $46^{\circ}\text{C}$ .

#### Operation ambient temperature expansion

(Cooling : $^{\circ}\text{CDB}$ , Heating : $^{\circ}\text{CWB}$ )

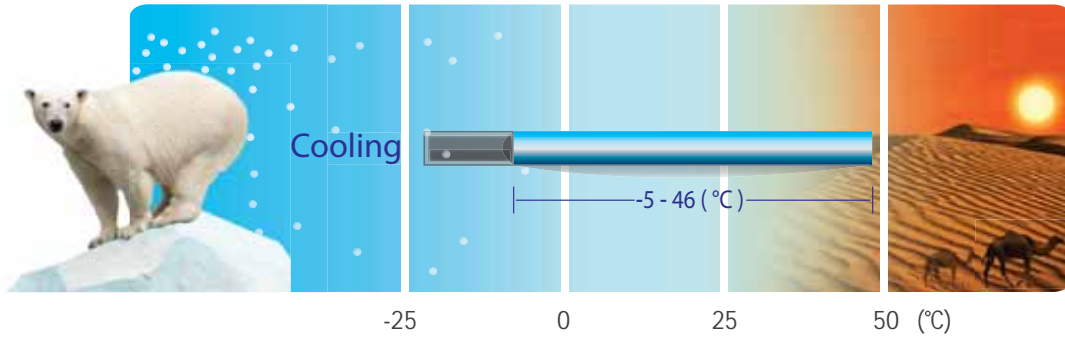

Note : Based on equivalent piping length of 7.5 m and piping height difference of 0 m.

### The external static pressure

The SMMS-e units are suitable for challenging installations where high external static pressure performance

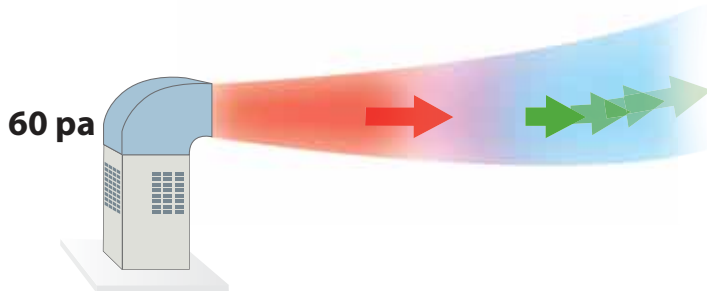

#### Air flow simulation diagram

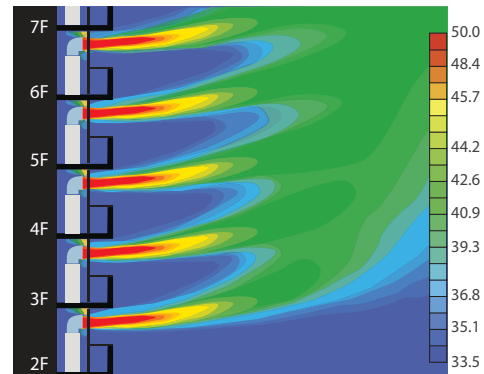



Note : This result is analytical simulation, that does not guarantee actual temperatures.





# Outdoor units

## Space saving model

									
Capacity		8HP	10HP	12HP	14HP	16HP	18HP	20HP	22HP
Model Name (MMY-)	50 Hz	MAP0806T8P-SG	MAP1006T8P-SG	MAP1206T8P-SG	MAP14B6T8P-SG	MAP1606T8P-SG	MAP18B6T8P-SG	MAP2006T8P-SG	MAP2206T8P-SG
Cooling capacity (kW)		22.4	28.0	33.5	40.0	45.0	50.4	56.0	61.5

											
Capacity		24HP	26HP	28HP	30HP	32HP	34HP	36HP	38HP		
Model Name (MMY-)	50 Hz	AP2416T8P-SG	AP2616T8P-SG	AP2816T8P-SG	AP3016T8P-SG	AP3216T8P-SG	AP3416T8P-SG	AP3616T8P-SG	AP3816T8P-SG		
Units in combination (MMY-MAP)		MAP1206T8P-SG	MAP1206T8P-SG	MAP14B6T8P-SG	MAP14B6T8P-SG	MAP14B6T8P-SG	MAP14B6T8P-SG	MAP1606T8P-SG	MAP1606T8P-SG	MAP1606T8P-SG	MAP1606T8P-SG
Cooling capacity (kW)		67.0	73.5	80.0	85.0	90.0	95.4	100.8	106.5		

												
Capacity		40HP		42HP		44HP		46HP		48HP		
Model Name (MMY-)	50 Hz	AP4016T8P-SG		AP4216T8P-SG		AP4416T8P-SG		AP4616T8P-SG		AP4816T8P-SG		
Units in combination (MMY-MAP)		MAP2206T8P-SG	MAP18B6T8P-SG	MAP2206T8P-SG	MAP2006T8P-SG	MAP2206T8P-SG	MAP2206T8P-SG	MAP1606T8P-SG	MAP1606T8P-SG	MAP14B6T8P-SG	MAP1606T8P-SG	MAP1606T8P-SG
Cooling capacity (kW)		111.9		117.5		123.0		130.0		135.0		





													
Capacity		50HP		52HP		54HP		56HP		58HP		60HP	
Model Name (MMY-)	50 Hz	AP5016T8P-SG		AP5216T8P-SG		AP5416T8P-SG		AP5616T8P-SG		AP5816T8P-SG		AP6016T8P-SG	
Units in combination (MMY-MAP)		MAP18B6T8P-SG	MAP1606T8P-SG	MAP1606T8P-SG	MAP18B6T8P-SG	MAP18B6T8P-SG	MAP18B6T8P-SG	MAP18B6T8P-SG	MAP18B6T8P-SG	MAP18B6T8P-SG	MAP18B6T8P-SG	MAP2206T8P-SG	MAP2206T8P-SG
Cooling capacity (kW)		140.4		145.8		151.2		156.8		162.3		168.0	



\* Power: 3-phase 50 Hz 400V (380 - 415V)  
 \* The source voltage must not fluctuate more than ±10%.  
 \* Rated conditions  
 Cooling: Indoor air temperature 27°C DB/19°C WB, outdoor air temperature 35°C DB



**High efficiency model**

					
Capacity		14HP	18HP	20HP	22HP
Model Name (MMY-)	50 Hz	MAP1406T8P-SG	MAP1806T8P-SG	AP2026T8P-SG	AP2226T8P-SG
Units in combination (MMY-MAP)		MAP1006T8P-SG MAP1006T8P-SG MAP1206T8P-SG MAP1006T8P-SG			
Cooling capacity (kW)		40.0	50.4	56.0	61.5

								
Capacity		26HP	28HP	30HP	34HP	36HP	38HP	
Model Name (MMY-)	50 Hz	AP2626T8P-SG	AP2826T8P-SG	AP3026T8P-SG	AP3426T8P-SG	AP3626T8P-SG	AP3826T8P-SG	
Units in combination (MMY-MAP)		MAP1406T8P	MAP1206T8P	MAP1406T8P	MAP1406T8P	MAP1606T8P	MAP1406T8P	MAP1206T8P
Cooling capacity (kW)		73.5	80.0	85.0	95.4	100.5	107.0	

										
Capacity		40HP	42HP				44HP		46HP	
Model Name (MMY-)	50 Hz	AP4026T8P-SG	AP4226T8P-SG				AP4426T8P-SG		AP4626T8P-SG	
Units in combination (MMY-MAP)		MAP1406T8P-SG	MAP1406T8P-SG	MAP1206T8P-SG	MAP1406T8P-SG	MAP1406T8P-SG	MAP1406T8P-SG	MAP1606T8P-SG	MAP1406T8P-SG	MAP1406T8P-SG
Cooling capacity (kW)		113.5	120.0				125.0		130.0	

													
Capacity		50HP	52HP	54HP	56HP	58HP							
Model Name (MMY-)	50 Hz	AP5026T8P-SG	AP5226T8P-SG	AP5426T8P-SG	AP5626T8P-SG	AP5826T8P-SG							
Units in combination (MMY-MAP)		MAP1806T8P-SG	MAP1606T8P-SG	MAP1606T8P-SG	MAP2006T8P-SG	MAP1606T8P-SG	MAP2006T8P-SG	MAP1406T8P-SG	MAP2006T8P-SG	MAP1606T8P-SG	MAP2206T8P-SG	MAP2006T8P-SG	MAP1606T8P-SG
Cooling capacity (kW)		140.4	146.0	152.0	157.0	162.5							

	Y-shape branching joint				Branch headers				Outdoor unit connection piping kit	
Appearance										
Model name	RBM-BY55E	RBM-BY105E	RBM-BY205E	RBM-BY305E	RBM-HY1043E	RBM-HY2043E	RBM-HY1083E	RBM-HY2083E	RBM-BT14E	RBM-BT24E
Usage (Classification according to indoor unit capacity code )	Total below 6.4	Total 6.4 or more and below 14.2	Total 14.2 or more and below 25.2	Total 25.2 or more	Max.4 branches		Max.8 branches		Total below 26.0	Total 26.0 or more
					Total below 14.2	Total 14.2 or more and below 25.2	Total below 14.2	Total 14.2 or more and below 25.2		

※ Anti-Corrosion protection model : MMY-MAP\*\*\*\*HT8JP

## Outdoor unit specifications

Space saving model (Single unit)

Equivalent HP		8HP	10HP	12HP	14HP	16HP
Model name	50Hz (MMY-)	MAP0806T8P-SG	MAP1006T8P-SG	MAP1206T8P-SG	MAP14B6T8P-SG	MAP1606T8P-SG
Outdoor unit type		Inverter				
Power supply (*1)		3phase 4wires 50Hz 400V (380-415V)				
Cooling (*2)	Capacity 100%	(kW) 22.4	28.0	33.5	40.0	45.0
	Power consumption	(kW) 5.23	7.33	9.41	13.7	13.7
	Starting current		Soft start	Soft start	Soft start	Soft start
	Running current	(A) 8.3	11.5	14.6	21.0	21.5
	EER (Energy Efficiency Ratio)	Capacity 100%	4.28	3.82	3.56	2.92
	Capacity 50%	6.39	6.22	5.86	4.88	5.45
External dimensions (Height / Width / Depth)	(mm)	1,800 / 990 / 780	1,800 / 990 / 780	1,800 / 990 / 780	1,800 / 990 / 780	1,800 / 1,210 / 780
Total weight	(kg)	240	240	240	240	298
Compressor	Motor output	(kW) 2.1 x 2	3.1 x 2	3.9 x 2	5.4 x 2	5.8 x 2
Fan unit	Motor output	(kW) 1.0	1.0	1.0	1.0	1.0
	Air volume	(m <sup>3</sup> /h) 9,700	9,700	12,200	12,200	12,600
Refrigerant piping	Main pipe diameter	Gas side (mm)	ø 19.1	ø 22.2	ø 28.6	ø 28.6
		Liquid side (mm)	ø 12.7	ø 12.7	ø 12.7	ø 15.9
		Balance pipe (mm)	ø 9.5	ø 9.5	ø 9.5	ø 9.5
Sound pressure level	(dB(A))	55	57	59	59	62
Diversity		170%	150%	135%	125%	135%
Recommended isolator	(A)	32	32	32	40	40

\* Individual isolator is recommended for each outdoor unit \*

Space saving model (Single unit)

Equivalent HP		18HP	20HP	22HP
Model name	50Hz MMY-	MAP18B6T8P-SG	MAP2006T8P-SG	MAP2206T8P-SG
Outdoor unit type		Inverter		
Power supply (*1)		3phase 4wires 50Hz 400V (380-415V)		
Cooling (*2)	Capacity 100%	(kW) 50.4	56.0	61.5
	Power consumption	(kW) 17.2	18.0	21.0
	Starting current		Soft start	Soft start
	Running current	(A) 26.7	27.9	32.2
	EER (Energy Efficiency Ratio)	Capacity 100%	2.93	3.11
	Capacity 50%	4.62	5.38	5.34
External dimensions (Height / Width / Depth)	(mm)	1,800/1,210/780	1,800/1,600/780	1,800/1,600/780
Total weight	(kg)	298	369	369
Compressor	Motor output	(kW) 6.9 x 2	7.6 x 2	9.0 x 2
Fan unit	Motor output	(kW) 1.0	2.0	2.0
	Air volume	(m <sup>3</sup> /h) 12,600	17,900	18,500
Refrigerant piping	Main pipe diameter	Gas side (mm)	ø 28.6	ø 28.6
		Liquid side (mm)	ø 15.9	ø 15.9
		Balance pipe (mm)	ø 9.5	ø 9.5
Sound pressure level	(dB(A))	62	61	61
Diversity		130%	140%	135%
Recommended isolator	(A)	63	63	63

\* Individual isolator is recommended for each outdoor unit \*

## Space saving model (Combination)

## Technical specifications

Equivalent HP			24HP		26HP		28HP	
Model name	50Hz	MMY-	AP2416T8P-SG		AP2616T8P-SG		AP2816T8P-SG	
Outdoor unit type	Inverter							
Power supply (*)	3phase 4wires 50Hz 400V (380-415V)							
Outdoor unit model	50Hz	MMY-	MAP1206T8P-SG	MAP1206T8P-SG	MAP14B6T8P-SG	MAP1206T8P-SG	MAP14B6T8P-SG	MAP14B6T8P-SG
Cooling (*)	Capacity 100%	(kW)	67.0		73.5		80.0	
	Power consumption	(kW)	18.80		23.1		27.4	
	Starting current		Soft start		Soft start		Soft start	
	Running current	(A)	29.2		35.6		42.0	
	EER (Energy Efficiency Ratio)	Capacity 100%	3.56		3.18		2.92	
	Capacity 50%	5.86		5.28		4.88		
Total weight		(kg)	240	240	240	240	240	240
Compressor	Motor output	(kW)	3.9 x 2	3.9 x 2	5.4 x 2	3.9 x 2	5.4 x 2	5.4 x 2
Fan unit	Motor output	(kW)	1.0	1.0	1.0	1.0	1.0	1.0
	Air volume	(m <sup>3</sup> /h)	12,200	12,200	12,200	12,200	12,200	12,200
Refrigerant piping	Main pipe diameter	Gas side (mm)	ø 34.9		ø 34.9		ø 34.9	
		Liquid side (mm)	ø 19.1		ø 19.1		ø 19.1	
		Balance pipe (mm)	ø 9.5		ø 9.5		ø 9.5	
Sound pressure level		(dB(A))	62		62		62	
Diversity			135%		130%		125%	

## Space saving model (Combination)

## Technical specifications

Equivalent HP			30HP		32HP		34HP	
Model name	50Hz	MMY-	AP3016T8P-SG		AP3216T8P-SG		AP3416T8P-SG	
Outdoor unit type	Inverter							
Power supply (*)	3phase 4wires 50Hz 400V (380-415V)							
Outdoor unit model	50Hz	MMY-	MAP1606T8P-SG	MAP14B6T8P-SG	MAP1606T8P-SG	MAP1606T8P-SG	MAP18B6T8P-SG	MAP1606T8P-SG
Cooling (*)	Capacity 100%	(kW)	85.0		90.0		95.4	
	Power consumption	(kW)	27.4		27.4		30.9	
	Starting current		Soft start		Soft start		Soft start	
	Running current	(A)	42.5		43.0		48.2	
	EER (Energy Efficiency Ratio)	Capacity 100%	3.10		3.28		3.09	
	Capacity 50%	5.25		5.45		4.97		
Total weight		(kg)	298	240	298	298	298	298
Compressor	Motor output	(kW)	5.8 x 2	5.4 x 2	5.8 x 2	5.8 x 2	6.9 x 2	5.8 x 2
Fan unit	Motor output	(kW)	1.0	1.0	1.0	1.0	1.0	1.0
	Air volume	(m <sup>3</sup> /h)	12,600	12,200	12,600	12,600	12,600	12,600
Refrigerant piping	Main pipe diameter	Gas side (mm)	ø 34.9		ø 34.9		ø 34.9	
		Liquid side (mm)	ø 19.1		ø 19.1		ø 19.1	
		Balance pipe (mm)	ø 9.5		ø 9.5		ø 9.5	
Sound pressure level		(dB(A))	64		65		65	
Diversity			130%		135%		130%	

\*1 The source voltage must not flucture more than ±10%.

\*2 Rated conditions Cooling : Indoor air temperature 27°C DB/19°C WB, Outdoor air temperature 35°C DB

Based on equivalent piping length of 7.5 m and piping height difference of 0 m.

Space saving model (Combination)

										Technical specifications			
Equivalent HP			36HP		38HP		40HP						
Model name	50Hz	MMY-	AP3616T8P-SG		AP3816T8P-SG		AP4016T8P-SG						
Outdoor unit type	Inverter												
Power supply (*1)	3phase 4wires 50Hz 400V (380-415V)												
Outdoor unit model	50Hz	MMY-	MAP18B6T8P-SG	MAP18B6T8P-SG	MAP2206T8P-SG	MAP1606T8P-SG	MAP2206T8P-SG	MAP18B6T8P-SG					
Cooling (*2)	Capacity 100%	(kW)	100.8		106.5		111.9						
	Power consumption	(kW)	34.4		34.7		38.2						
	Starting current		Soft start		Soft start		Soft start						
	Running current	(A)	53.4		53.7		58.9						
	EER (Energy Efficiency Ratio)	Capacity 100%	2.93		3.07		2.93						
	Capacity 50%	4.62		5.46		4.99							
Total weight			298	298	369	298	369	298	298				
Compressor	Motor output	(kW)	6.9 × 2	6.9 × 2	9.0 × 2	5.8 × 2	9.0 × 2	6.9 × 2					
Fan unit	Motor output	(kW)	1.0	1.0	2.0	1.0	2.0	1.0					
	Air volume	(m <sup>3</sup> /h)	12,600	12,600	18,500	12,600	18,500	12,600					
Refrigerant piping	Main pipe diameter	Gas side (mm)	ø 41.3		ø 41.3		ø 41.3						
		Liquid side (mm)	ø 22.2		ø 22.2		ø 22.2						
		Balance pipe (mm)	ø 9.5		ø 9.5		ø 9.5						
Sound pressure level		(dB(A))	65		64.5		64.5						
Diversity			130%		135%		130%						

Space saving model (Combination)

													Technical specifications			
Equivalent HP			42HP		44HP		46HP			48HP						
Model name	50Hz	MMY-	AP4216T8P-SG		AP4416T8P-SG		AP4616T8P-SG			AP4816T8P-SG						
Outdoor unit type	Inverter															
Power supply (*1)	3phase 4wires 50Hz 400V (380-415V)															
Outdoor unit model	50Hz	MMY-	MAP2206T8P-SG	MAP2006T8P-SG	MAP2206T8P-SG	MAP2206T8P-SG	MAP1606T8P-SG	MAP1606T8P-SG	MAP14B6T8P-SG	MAP1606T8P-SG	MAP1606T8P-SG	MAP1606T8P-SG				
Cooling (*2)	Capacity 100%	(kW)	117.5		123.0		130.0			135.0						
	Power consumption	(kW)	39.0		42.0		41.1			41.1						
	Starting current		Soft start		Soft start		Soft start			Soft start						
	Running current	(A)	60.1		64.4		64.0			64.5						
	EER (Energy Efficiency Ratio)	Capacity 100%	3.01		2.93		3.16			3.28						
	Capacity 50%	5.36		5.34		5.26			5.45							
Total weight		(kg)	369	369	369	369	298	298	298	298	298	298				
Compressor	Motor output	(kW)	9.0 × 2	7.6 × 2	9.0 × 2	9.0 × 2	5.8 × 2	5.8 × 2	5.4 × 2	5.8 × 2	5.8 × 2	5.8 × 2				
Fan unit	Motor output	(kW)	2.0	2.0	2.0	2.0	1.0	1.0	1.0	1.0	1.0	1.0				
	Air volume	(m <sup>3</sup> /h)	18,500	17,900	18,500	18,500	12,600	12,600	12,200	12,600	12,600	12,600				
Refrigerant piping	Main pipe diameter	Gas side (mm)	ø 41.3		ø 41.3		ø 41.3			ø 41.3						
		Liquid side (mm)	ø 22.2		ø 22.2		ø 22.2			ø 22.2						
		Balance pipe (mm)	ø 9.5		ø 9.5		ø 9.5			ø 9.5						
Sound pressure level		(dB(A))	64		64		66			67						
Diversity			135%		135%		130%			135%						

## Space saving model (Combination)

Equivalent HP			50HP			52HP			54HP		
Model name	50Hz	MMY-	AP5016T8P-SG			AP5216T8P-SG			AP5416T8P-SG		
Outdoor unit type	Inverter										
Power supply (*2)	3phase 4wires 50Hz 400V (380-415V)										
Outdoor unit model	50Hz	MMY-	MAP18B6T8P-SG	MAP1606T8P-SG	MAP1606T8P-SG	MAP18B6T8P-SG	MAP18B6T8P-SG	MAP1606T8P-SG	MAP18B6T8P-SG	MAP18B6T8P-SG	MAP18B6T8P-SG
Cooling (*)	Capacity 100%	(kW)	140.4			145.8			151.2		
	Power consumption	(kW)	44.6			48.1			51.6		
	Starting current		Soft start			Soft start			Soft start		
	Running current	(A)	69.7			74.9			80.1		
	EER (Energy Efficiency Ratio)	Capacity 100%		3.15			3.03			2.93	
Capacity 50%			5.12			4.84			4.62		
Total weight		(kg)	298	298	298	298	298	298	298	298	298
Compressor	Motor output	(kW)	6.9 x 2	5.8 x 2	5.8 x 2	6.9 x 2	6.9 x 2	5.8 x 2	6.9 x 2	6.9 x 2	6.9 x 2
Fan unit	Motor output	(kW)	1.0	1.0	1.0	1.0	1.0	1.0	1.0	1.0	1.0
	Air volume	(m <sup>3</sup> /h)	12,600	12,600	12,600	12,600	12,600	12,600	12,600	12,600	12,600
Refrigerant piping	Main pipe diameter	Gas side (mm)	ø 41.3			ø 41.3			ø 41.3		
		Liquid side (mm)	ø 22.2			ø 22.2			ø 22.2		
		Balance pipe (mm)	ø 9.5			ø 9.5			ø 9.5		
Sound pressure level		(dB(A))	67			67			67		
Diversity			130%			130%			130%		

## Space saving model (Combination)

Equivalent HP			56HP			58HP			60HP		
Model name	50Hz	MMY-	AP5616T8P-SG			AP5816T8P-SG			AP6016T8P-SG		
Outdoor unit type	Inverter										
Power supply (*2)	3phase 4wires 50Hz 400V (380-415V)										
Outdoor unit model	50Hz	MMY-	MAP2006T8P-SG	MAP18B6T8P-SG	MAP18B6T8P-SG	MAP2206T8P-SG	MAP18B6T8P-SG	MAP18B6T8P-SG	MAP2206T8P-SG	MAP2206T8P-SG	MAP1606T8P-SG
Cooling (*)	Capacity 100%	(kW)	156.8			162.3			168.0		
	Power consumption	(kW)	52.4			55.4			55.7		
	Starting current		Soft start			Soft start			Soft start		
	Running current	(A)	81.3			85.6			85.9		
	EER (Energy Efficiency Ratio)	Capacity 100%		2.99			2.93			3.02	
Capacity 50%			4.86			4.87			5.37		
Total weight		(kg)	369	298	298	369	298	298	369	369	298
Compressor	Motor output	(kW)	7.6 x 2	6.9 x 2	6.9 x 2	9.0 x 2	6.9 x 2	6.9 x 2	9.0 x 2	9.0 x 2	5.8 x 2
Fan unit	Motor output	(kW)	2.0	1.0	1.0	2.0	1.0	1.0	2.0	2.0	1.0
	Air volume	(m <sup>3</sup> /h)	17,900	12,600	12,600	18,500	12,600	12,600	18,500	18,500	12,600
Refrigerant piping	Main pipe diameter	Gas side (mm)	ø 41.3			ø 41.3			ø 41.3		
		Liquid side (mm)	ø 22.2			ø 22.2			ø 22.2		
		Balance pipe (mm)	ø 9.5			ø 9.5			ø 9.5		
Sound pressure level		(dB(A))	66.5			66.5			66.5		
Diversity			135%			130%			135%		

\*1 The source voltage must not flucture more than  $\pm 10\%$ .

\*2 Rated conditions Cooling : Indoor air temperature 27°C DB/19°C WB, Outdoor air temperature 35°C DB

The standard piping means that main pipe length is 5m, branching pipe length is 2.5m of branch piping connected with a 0 meter height.

## High efficiency model (Single unit)

**Technical specifications**

Equivalent HP		14HP	18HP
Model name	50Hz (MMY-)	MAP1406T8P-SG	MAP1806T8P-SG
Outdoor unit type	Inverter		
Power supply (*1)	3phase 4wires 50Hz 400V (380-415V)		
Cooling (*2)	Capacity 100%	40.0	50.4
	Power consumption	119	14.0
	Starting current	Soft start	Soft start
	Running current	18.2	22.0
	EER (Energy Efficiency Ratio)		
	Capacity 100%	3.36	3.60
	Capacity 50%	5.31	5.29
External dimensions (Height / Width / Depth)	(mm)	1,800 / 1,210 / 780	1,800 / 1,600 / 780
Total weight	(kg)	298	369
Compressor	Motor output	4.8 x 2	6.5 x 2
Fan unit	Motor output	1.0	2.0
	Air volume	12,200	17,300
Refrigerant piping	Main pipe diameter	Gas side (mm)	ø 28.6
		Liquid side (mm)	ø 15.9
		Balance pipe (mm)	ø 9.5
Sound pressure level	(dB(A))	60	60
Diversity		145%	150%
Recommended isolator	(A)	40	63

\* Individual isolator is recommended for each outdoor unit \*

## High efficiency model (Combination)

Equivalent HP			20HP		22HP		26HP	
Model name	50Hz	MMY-	AP2026T8P-SG		AP2226T8P-SG		AP2626T8P-SG	
Outdoor unit type	Inverter							
Power supply (*1)	3phase 4wires 50Hz 400V (380-415V)							
Outdoor unit model	50Hz	MMY-	MAP1006T8P-SG	MAP1006T8P-SG	MAP1206T8P-SG	MAP1006T8P-SG	MAP1406T8P-SG	MAP1206T8P-SG
Cooling (*2)	Capacity 100%	(kW)	56.0		61.5		73.5	
	Power consumption	(kW)	14.7		16.7		21.3	
	Starting current		Soft start		Soft start		Soft start	
	Running current	(A)	23.0		26.1		32.8	
	EER (Energy Efficiency Ratio)	Capacity 100%	3.82		3.67		3.45	
	Capacity 50%	6.22		6.02		5.55		
Total weight		(kg)	240	240	240	240	298	240
Compressor	Motor output	(kW)	3.1 x 2	3.1 x 2	3.9 x 2	3.1 x 2	4.8 x 2	3.9 x 2
	Motor output	(kW)	1.0	1.0	1.0	1.0	1.0	1.0
Fan unit	Air volume	(m <sup>3</sup> /h)	9,700	9,700	12,200	9,700	12,200	12,200
	Refrigerant piping	Main pipe diameter	Gas side (mm)	ø 28.6		ø 28.6		ø 34.9
Liquid side (mm)			ø 15.9		ø 19.1		ø 19.1	
Balance pipe (mm)			ø 9.5		ø 9.5		ø 9.5	
Sound pressure level		(dB(A))	60		61.5		62.5	
Diversity			150%		140%		140%	

## High efficiency / model (Combination)

Equivalent HP			28HP		30HP		34HP	
Model name	50Hz	MMY-	AP2826T8P-SG		AP3026T8P-SG		AP3426T8P-SG	
Outdoor unit type	Inverter							
Power supply (*1)	3phase 4wires 50Hz 400V (380-415V)							
Outdoor unit model	50Hz	MMY-	MAP1406T8P-SG	MAP1406T8P-SG	MAP1606T8P-SG	MAP1406T8P-SG	MAP1806T8P-SG	MAP1606T8P-SG
Cooling (*2)	Capacity 100%	(kW)	80.0		85.0		95.4	
	Power consumption	(kW)	23.8		25.6		27.7	
	Starting current		Soft start		Soft start		Soft start	
	Running current	(A)	36.4		39.7		43.5	
	EER (Energy Efficiency Ratio)	Capacity 100%	3.36		3.32		3.44	
	Capacity 50%	5.31		5.38		5.37		
Total weight		(kg)	298	298	298	298	369	298
Compressor	Motor output	(kW)	4.8 x 2	4.8 x 2	5.8 x 2	4.8 x 2	6.5 x 2	5.8 x 2
	Motor output	(kW)	1.0	1.0	1.0	1.0	2.0	1.0
Fan unit	Air volume	(m <sup>3</sup> /h)	12,200	12,200	12,600	12,200	17,300	12,600
	Refrigerant piping	Main pipe diameter	Gas side (mm)	ø 34.9		ø 34.9		ø 34.9
Liquid side (mm)			ø 19.1		ø 19.1		ø 19.1	
Balance pipe (mm)			ø 9.5		ø 9.5		ø 9.5	
Sound pressure level		(dB(A))	63		64.5		64.5	
Diversity			145%		140%		140%	

 \*1 The source voltage must not fluctuate more than  $\pm 10\%$ .

\*2 Rated conditions Cooling : Indoor air temperature 27°C DB/19°C WB, Outdoor air temperature 35°C DB

Based on equivalent piping length of 7.5 m and piping height difference of 0 m.

## High efficiency model (Combination)

Equivalent HP		36HP			38HP			40HP			
Model name	50Hz MMY-	AP3626T8P-SG			AP3826T8P-SG			AP4026T8P-SG			
Outdoor unit type	Inverter										
Power supply (*1)	3phase 4wires 50Hz 400V (380-415V)										
Outdoor unit model	50Hz MMY-	MAP1206T8P-SG	MAP1206T8P-SG	MAP1206T8P-SG	MAP1406T8P-SG	MAP1206T8P-SG	MAP1206T8P-SG	MAP1406T8P-SG	MAP1406T8P-SG	MAP1206T8P-SG	
Cooling (*2)	Capacity 100%	100.5			107.0			113.5			
	Power consumption	28.2			30.7			33.2			
	Starting current	Soft start			Soft start			Soft start			
	Running current	43.8			47.4			51.0			
	EER (Energy Efficiency Ratio)	Capacity 100%	3.56			3.48			3.42		
	Capacity 50%	5.86			5.64			5.46			
Total weight	(kg)	240	240	240	298	240	240	298	298	240	
Compressor	Motor output (kW)	3.9 x 2	3.9 x 2	3.9 x 2	4.8 x 2	3.9 x 2	3.9 x 2	4.8 x 2	4.8 x 2	3.9 x 2	
Fan unit	Motor output (kW)	1.0	1.0	1.0	1.0	1.0	1.0	1.0	1.0	1.0	
	Air volume (m <sup>3</sup> /h)	12,200	12,200	12,200	12,200	12,200	12,200	12,200	12,200	12,200	
Refrigerant piping	Main pipe diameter	Gas side (mm)	ø 41.3			ø 41.3			ø 41.3		
		Liquid side (mm)	ø 22.2			ø 22.2			ø 22.2		
		Balance pipe (mm)	ø 9.5			ø 9.5			ø 9.5		
Sound pressure level	(dB(A))	64			64.5			64.5			
Diversity		135%			140%			140%			

## High efficiency /model (Combination)

Equivalent HP		42HP			44HP			46HP			
Model name	50Hz MMY-	AP4226T8P-SG			AP4426T8P-SG			AP4626T8P-SG			
Outdoor unit type	Inverter										
Power supply (*1)	3phase 4wires 50Hz 400V (380-415V)										
Outdoor unit model	50Hz MMY-	MAP1406T8P-SG	MAP1406T8P-SG	MAP1406T8P-SG	MAP1606T8P-SG	MAP1406T8P-SG	MAP1406T8P-SG	MAP1606T8P-SG	MAP1606T8P-SG	MAP1406T8P-SG	
Cooling (*2)	Capacity 100%	1200			125.0			130.0			
	Power consumption	35.7			37.5			39.3			
	Starting current	Soft start			Soft start			Soft start			
	Running current	54.6			57.9			61.2			
	EER (Energy Efficiency Ratio)	Capacity 100%	3.36			3.33			3.31		
	Capacity 50%	5.31			5.36			5.40			
Total weight	(kg)	298	298	298	298	298	298	298	298	298	
Compressor	Motor output (kW)	4.8 x 2	4.8 x 2	4.8 x 2	5.8 x 2	4.8 x 2	4.8 x 2	5.8 x 2	5.8 x 2	4.8 x 2	
Fan unit	Motor output (kW)	1.0	1.0	1.0	1.0	1.0	1.0	1.0	1.0	1.0	
	Air volume (m <sup>3</sup> /h)	12,200	12,200	12,200	12,600	12,200	12,200	12,600	12,600	12,200	
Refrigerant piping	Main pipe diameter	Gas side (mm)	ø 41.3			ø 41.3			ø 41.3		
		Liquid side (mm)	ø 22.2			ø 22.2			ø 22.2		
		Balance pipe (mm)	ø 9.5			ø 9.5			ø 9.5		
Sound pressure level	(dB(A))	65			65.5			66.5			
Diversity		145%			140%			140%			

## High efficiency / model (Combination)

Equivalent HP			50HP			52HP			54HP		
Model name	50Hz	MMY-	AP5026T8P-SG			AP5226T8P-SG			AP5426T8P-SG		
Outdoor unit type	Inverter										
Power supply (*2)	3phase 4wires 50Hz 400V (380-415V)										
Outdoor unit model	50Hz	MMY-	MAP1806T8P-SG	MAP1606T8P-SG	MAP1606T8P-SG	MAP2006T8P-SG	MAP1606T8P-SG	MAP1606T8P-SG	MAP2006T8P-SG	MAP2006T8P-SG	MAP1406T8P-SG
Cooling (*1)	Capacity 100%	(kW)	140.4			146.0			152.0		
	Power consumption	(kW)	41.4			45.4			47.9		
	Starting current		Soft start			Soft start			Soft start		
	Running current	(A)	65.0			70.9			74.0		
	EER (Energy Efficiency Ratio)	Capacity 100%		3.39			3.22			3.17	
Capacity 50%			5.39			5.42			5.36		
Total weight		(kg)	369	298	298	369	298	298	369	369	298
Compressor	Motor output	(kW)	6.5 x 2	5.8 x 2	5.8 x 2	7.6 x 2	5.8 x 2	5.8 x 2	7.6 x 2	7.6 x 2	4.8 x 2
Fan unit	Motor output	(kW)	2.0	1.0	1.0	2.0	1.0	1.0	2.0	2.0	1.0
	Air volume	(m <sup>3</sup> /h)	17,300	12,600	12,600	17,900	12,600	12,600	17,900	17,900	12,200
Refrigerant piping	Main pipe diameter	Gas side (mm)	ø 41.3			ø 41.3			ø 41.3		
		Liquid side (mm)	ø 22.2			ø 22.2			ø 22.2		
		Balance pipe (mm)	ø 9.5			ø 9.5			ø 9.5		
Sound pressure level		(dB(A))	66.5			66.5			65.5		
Diversity			140%			135%			145%		

## High efficiency / model (Combination)

Equivalent HP			56HP			58HP		
Model name	50Hz	MMY-	AP5626T8P-SG			AP5826T8P-SG		
Outdoor unit type	Inverter							
Power supply (*2)	3phase 4wires 50Hz 400V (380-415V)							
Outdoor unit model	50Hz	MMY-	MAP2006T8P-SG	MAP2006T8P-SG	MAP1606T8P-SG	MAP2006T8P-SG	MAP2006T8P-SG	MAP1606T8P-SG
Cooling (*1)	Capacity 100%	(kW)	157.0			162.5		
	Power consumption	(kW)	49.7			52.7		
	Starting current		Soft start			Soft start		
	Running current	(A)	77.3			81.6		
	EER (Energy Efficiency Ratio)	Capacity 100%		3.16			3.08	
Capacity 50%			5.40			5.38		
Total weight		(kg)	369	369	298	369	369	298
Compressor	Motor output	(kW)	7.6 x 2	7.6 x 2	5.8 x 2	9.0 x 2	7.6 x 2	5.8 x 2
Fan unit	Motor output	(kW)	2.0	2.0	1.0	2.0	2.0	1.0
	Air volume	(m <sup>3</sup> /h)	17,900	17,900	12,600	18,500	17,900	12,600
Refrigerant piping	Main pipe diameter	Gas side (mm)	ø 41.3			ø 41.3		
		Liquid side (mm)	ø 22.2			ø 22.2		
		Balance pipe (mm)	ø 9.5			ø 9.5		
Sound pressure level		(dB(A))	66.5			66.5		
Diversity			140%			135%		

\*1 The source voltage must not flucture more than ±10%.

\*2 Rated conditions Cooling : Indoor air temperature 27°C DB/19°C WB, Outdoor air temperature 35°C DB

The standard piping means that main pipe length is 5m, branching pipe length is 2.5m of branch piping connected with a 0 meter height.

## Outdoor units external drawings

**Model : MMY-MAP0806T8P-SG  
 MMY-MAP1006T8P-SG  
 MMY-MAP1206T8P-SG  
 MMY-MAP14B6T8P-SG**

Model Name	øA
MAP0806 type	ø19.1
MAP1006 type	ø22.2
MAP1206 type	ø28.6
MAP14B6 type	ø28.6

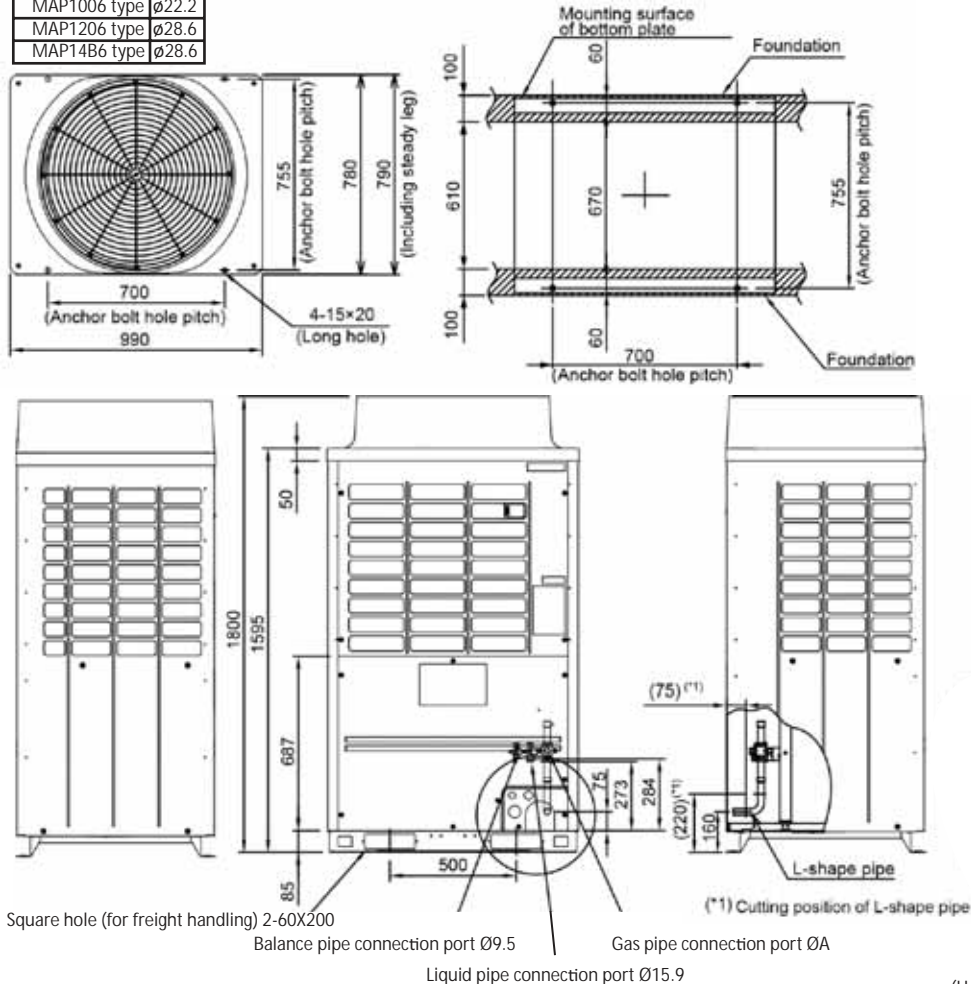

(Note)

1. IF there is an obstacle at the upper side of the outdoor unit, set the top end of the outdoor unit 2000mm apart from the obstacle
2. Limit the height of the obstacle surrounding the outdoor unit to 800mm or less from the bottom end of the outdoor unit.
3. Draw out the pipe procured locally to the front of the outdoor unit horizontally and keep 500mm or more between the outdoor unit and traversing pipe if placing pipe transversely.
4. Dimensional drawing of corrosion heavy protection model is the same as that of standard model.

(Unit:mm)

**Model : MMY-MAP1406T8P-SG  
MMY-MAP1606T8P-SG  
MMY-MAP18B6T8P-SG**

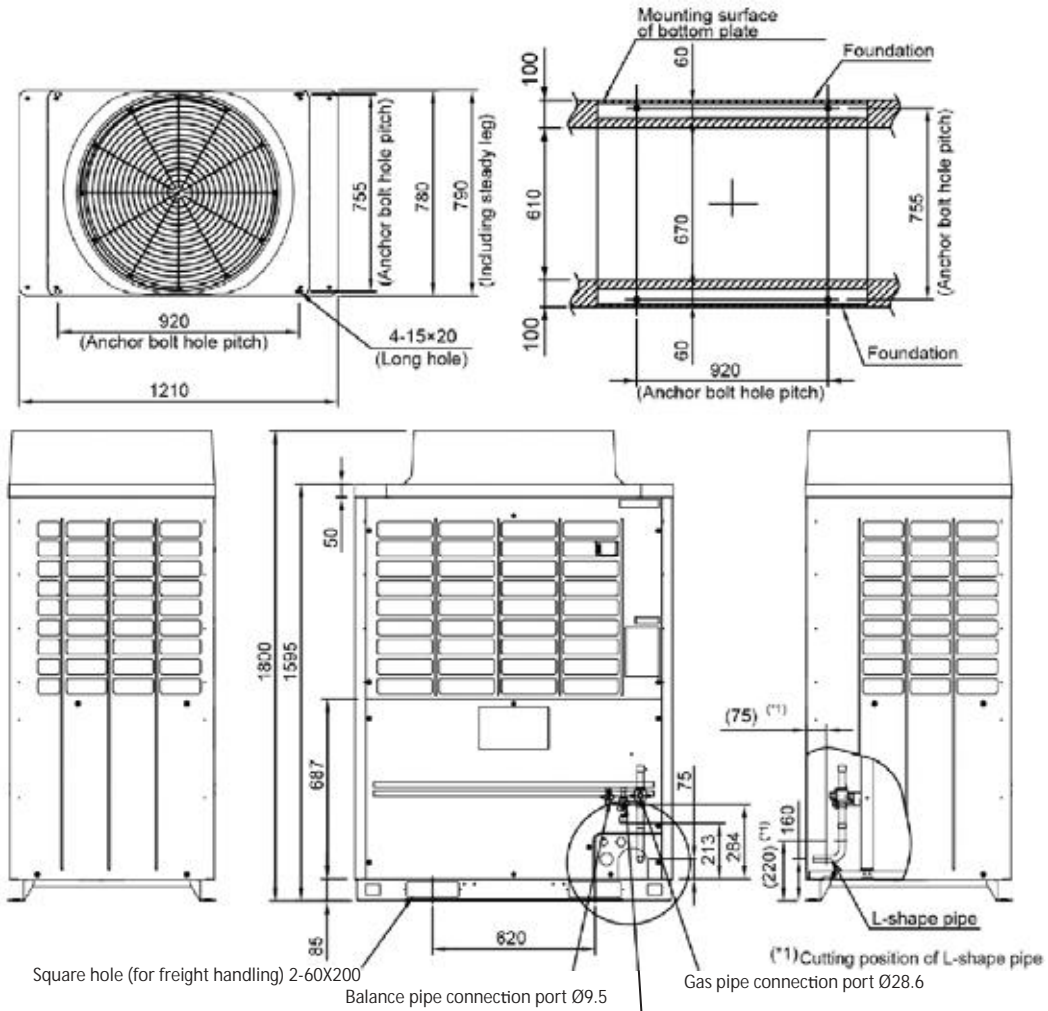

(Note)

1. IF there is an obstacle at the upper side of the outdoor unit, set the top end of the outdoor unit 2000mm apart from the obstacle
2. Limit the height of the obstacle surrounding the outdoor unit to 800mm or less from the bottom end of the outdoor unit.
3. Draw out the pipe procured locally to the front of the outdoor unit horizontally and keep 500mm or more between the outdoor unit and traversing pipe if placing pipe transversely.
4. Dimensional drawing of corrosion heavy protection model is the same as that of standard model.

Liquid pipe connection port Ø15.9

(Unit:mm)

**Model : MMY-MAP1806T8P-SG  
MMY-MAP2006T8P-SG  
MMY-MAP2206T8P-SG**

Model Name	φA
MAP1806 type	φ15.9
MAP2006 type	φ15.9
MAP2206 type	φ19.1

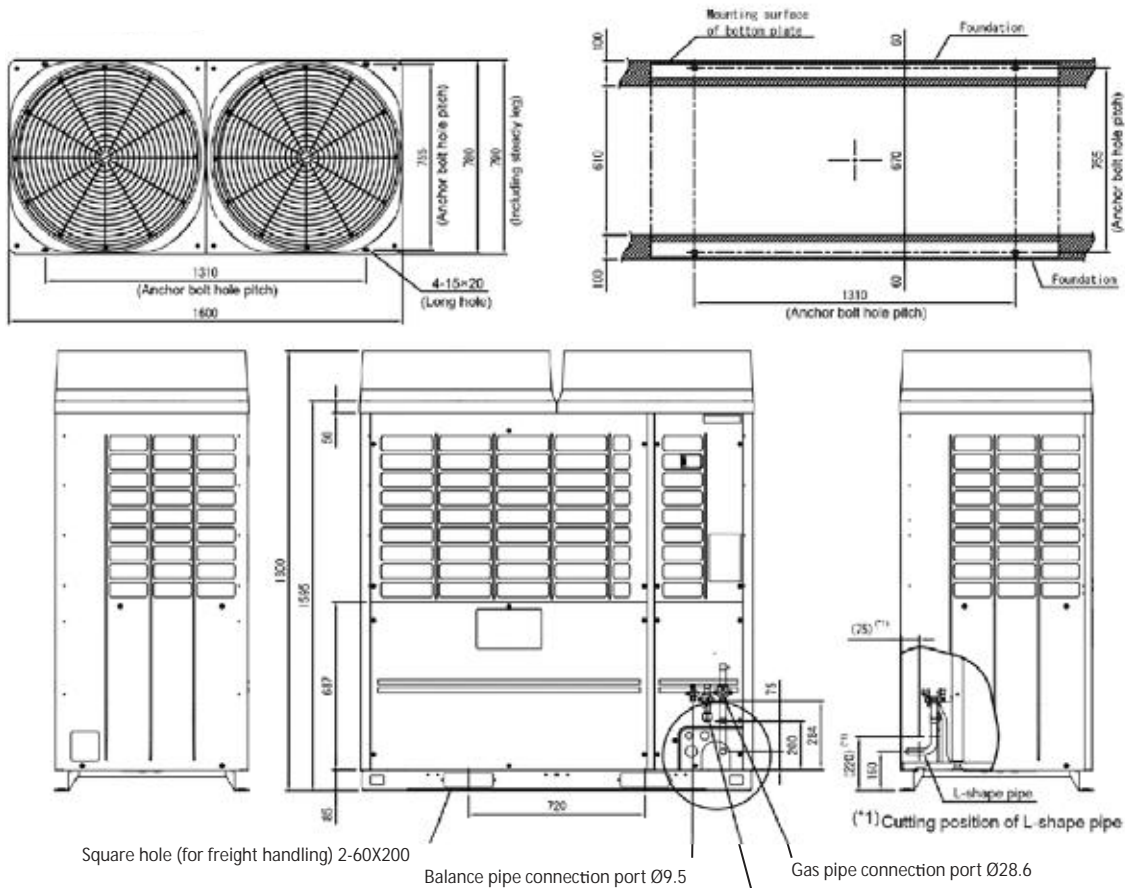

**(Note)**

1. IF there is an obstacle at the upper side of the outdoor unit, set the top end of the outdoor unit 2000mm apart from the obstacle
2. Limit the height of the obstacle surrounding the outdoor unit to 800mm or less from the bottom end of the outdoor unit.
3. Draw out the pipe procured locally to the front of the outdoor unit horizontally and keep 500mm or more between the outdoor unit and traversing pipe if placing pipe transversely.
4. Dimensional drawing of corrosion heavy protection model is the same as that of standard model.

(Unit:mm)





## Indoor units

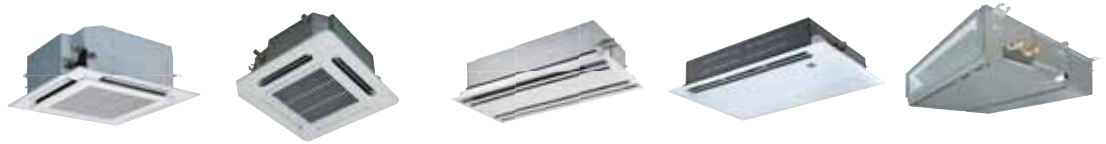

Cooling capacity (HP equivalent)	4-way air discharge cassette type	Compact 4-way cassette (600 × 600) type	2-way air discharge cassette type	1-way air discharge cassette type	Concealed duct type
007 type 2.2 kW (0.8HP)		MMU-AP0074MH-E	MMU-AP0072WH	MMU-AP0074YH-E	MMD-AP0076BHP-E
009 type 2.8 kW (1HP)	MMU-AP0094HP-E	MMU-AP0094MH-E	MMU-AP0092WH	MMU-AP0094YH-E	MMD-AP0096BHP-E
012 type 3.6 kW (1.25HP)	MMU-AP0124HP-E	MMU-AP0124MH-E	MMU-AP0122WH	MMU-AP0124YH-E	MMD-AP0126BHP-E
015 type 4.5 kW (1.7HP)	MMU-AP0154HP-E	MMU-AP0154MH-E	MMU-AP0152WH	MMU-AP0154SH-E	MMD-AP0156BHP-E
018 type 5.6 kW (2HP)	MMU-AP0184HP-E	MMU-AP0184MH-E	MMU-AP0182WH	MMU-AP0184SH-E	MMD-AP0186BHP-E
024 type 7.1 kW (2.5HP)	MMU-AP0244HP-E		MMU-AP0242WH	MMU-AP0244SH-E	MMD-AP0246BHP-E
027 type 8.0 kW (3HP)	MMU-AP0274HP-E		MMU-AP0272WH		MMD-AP0276BHP-E
030 type 9.0 kW (3.2HP)	MMU-AP0304HP-E		MMU-AP0302WH		MMD-AP0306BHP-E
036 type 11.2 kW (4HP)	MMU-AP0364HP-E		MMU-AP0362WH		MMD-AP0366BHP-E
048 type 14.0 kW (5HP)	MMU-AP0484HP-E		MMU-AP0482WH		MMD-AP0486BHP-E
056 type 16.0kW (6HP)	MMU-AP0564HP-E		MMU-AP0562WH		MMD-AP0566BHP-E
072 type 22.4kW (8HP)					
096 type 28.0kW (10HP)					



Cooling capacity (HP equivalent)	Concealed duct high static pressure type	Slim duct type	Ceiling type	High wall type 3 series
007 type 2.2 kW (0.8HP)		MMD-AP0074SPH-E		MMK-AP0073H
009 type 2.8 kW (1HP)		MMD-AP0094SPH-E		MMK-AP0093H
012 type 3.6 kW (1.25HP)		MMD-AP0124SPH-E		MMK-AP0123H
015 type 4.5 kW (1.7HP)		MMD-AP0154SPH-E	MMC-AP0157HP-E	MMK-AP0153H
018 type 5.6 kW (2HP)	MMD-AP0186HP-E	MMD-AP0184SPH-E	MMC-AP0187HP-E	MMK-AP0183H
024 type 7.1 kW (2.5HP)	MMD-AP0246HP-E	MMD-AP0244SPH-E	MMC-AP0247HP-E	MMK-AP0243H
027 type 8.0 kW (3HP)	MMD-AP0276HP-E	MMD-AP0274SPH-E	MMC-AP0277HP-E	
030 type 9.0 kW (3.2HP)				
036 type 11.2 kW (4HP)	MMD-AP0366HP-E		MMC-AP0367HP-E	
048 type 14.0 kW (5HP)	MMD-AP0486HP-E		MMC-AP0487HP-E	
056 type 16.0kW (6HP)	MMD-AP0566HP-E		MMC-AP0567HP-E	
072 type 22.4kW (8HP)	MMD-AP0726HP-E			
096 type 28.0 kW (10HP)	MMD-AP0966HP-E			



Cooling capacity (HP equivalent)	Console	Floor standing cabinet type	Floor standing concealed type	Floor standing type	Large capacity floor standing type
007 type 2.2 kW (0.8HP)	MML-AP0074NH-E	MML-AP0074H-E	MML-AP0074BH-E		
009 type 2.8 kW (1HP)	MML-AP0094NH-E	MML-AP0094H-E	MML-AP0094BH-E		
012 type 3.6 kW (1.25HP)	MML-AP0124NH-E	MML-AP0124H-E	MML-AP0124BH-E		
015 type 4.5 kW (1.7HP)	MML-AP0154NH-E	MML-AP0154H-E	MML-AP0154BH-E	MMF-AP0156H-E	
018 type 5.6 kW (2HP)	MML-AP0184NH-E	MML-AP0184H-E	MML-AP0184BH-E	MMF-AP0186H-E	
024 type 7.1 kW (2.5HP)		MML-AP0244H-E	MML-AP0244BH-E	MMF-AP0246H-E	
027 type 8.0 kW (3HP)				MMF-AP0276H-E	
030 type 9.0 kW (3.2HP)					
036 type 11.2 kW (4HP)				MMF-AP0366H-E	
048 type 14.0 kW (5HP)				MMF-AP0486H-E	
056 type 16.0 kW (6HP)				MMF-AP0566H-E	
072 type 22.4 kW (8HP)					MMF-AP0723DH-V/H-VA/VB
096 type 28.0 kW (10HP)					MMF-AP0963DH-V/H-VA/VB
144 type 45.0 kW (16HP)					MMF-AP1443DH-V/H-VA/VB
192 type 56.0 kW (20HP)					MMF-AP1923DH-V/H-VA/VB



Air volume	Air-to-air heat exchanger with DX-coil type	Fresh air intake Indoor unit type
150 m <sup>3</sup> /h		
250 m <sup>3</sup> /h		
350 m <sup>3</sup> /h		
500 m <sup>3</sup> /h	MMD-VN502HEXE	
650 m <sup>3</sup> /h		
800 m <sup>3</sup> /h	MMD-VN800HEXE	
1000 m <sup>3</sup> /h	MMD-VN1002HEXE/2	
1500 m <sup>3</sup> /h		
2000 m <sup>3</sup> /h		
1080 m <sup>3</sup> /h		MMD-AP0481HFE
1680 m <sup>3</sup> /h		MMD-AP0721HFE
2100 m <sup>3</sup> /h		MMD-AP0961HFE

Air volume	Air-to-air heat exchange r*
150 m <sup>3</sup> /h	VN-M150HE
250 m <sup>3</sup> /h	VN-M250HE
350 m <sup>3</sup> /h	VN-M350HE
500 m <sup>3</sup> /h	VN-M500HE
650 m <sup>3</sup> /h	VN-M650HE
800 m <sup>3</sup> /h	VN-M800HE
1000 m <sup>3</sup> /h	VN-M1000HE
1500 m <sup>3</sup> /h	VN-M1500HE
2000 m <sup>3</sup> /h	VN-M2000HE

\*: Does not connect to refrigerant piping from outdoor unit. Control wires can be connected.



## 4-way Air Discharge Cassette Type

MMU-AP\*\*\*4HP-E

### Individual louver control

The angles of each of the four louver can be set individually  
=> Enables airflow to be adapted to user preferences.

### Easy installation

The panel is attached using the bolt already installed on the indoor unit.

(1) Standard swing



(2) Diagonally opposite swing

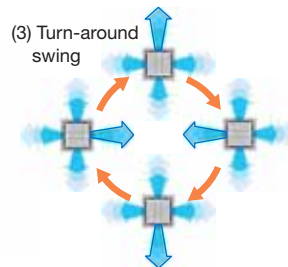

Note: RBC-AMT32E, RBC-AMS51E only

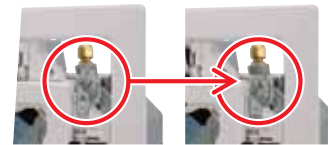

RBC-U31PGP(W)-E

## Technical specifications

Model name		MMU-	AP0094HP-E	AP0124HP-E	AP0154HP-E	AP0184HP-E	AP0244HP-E	AP0274HP-E	AP0304HP-E	AP0364HP-E	AP0484HP-E	AP0564HP-E	
Cooling		(kW)	2.8	3.6	4.5	5.6	7.1	8.0	9.0	11.2	14.0	16.0	
Electrical characteristics	Power requirements	1-phase 50Hz 230V (220-240V)											
	Power consumption 50 Hz (kW)		0.021		0.023	0.026		0.036	0.043	0.088	0.112	0.112	
Appearance (Ceiling panel)		Model	RBC-U31PGP(W)-E										
External dimensions: Main unit (Ceiling panel)*	Height (mm)		256 (30)*						319 (30)*				
	Width (mm)		840 (950)*										
	Depth (mm)		840 (950)*										
Total weight: Main unit (Ceiling panel)*		(kg)	18 (4)*		20 (4)*				25 (4)*				
Fan unit	Standard air flow (High/Mid/Low) (m <sup>3</sup> /h)		800/730/680		930/830/790	1050/920/800	1290/920/800		1320/1110/850	1970/1430/1070	2130/1430/1130	2130/1520/1230	
	Motor output (W)		14				20			68	72		
Connecting pipe	Gas side (mm)		ø9.5		ø12.7		ø15.9						
	Liquid side (mm)		ø6.4				ø9.5						
	Drain port (nominal dia.) (mm)		25 (Polyvinyl chloride tube)										
Sound pressure level*2 (High/Mid/Low) (dB(A))			30/29/27		31/29/27	32/29/27	35/31/28		38/33/30	43/38/32	46/38/33	46/40/33	

\* Figures in parentheses are for ceiling panels.

Note 1 : The capacities are measured under the conditions specified by JIS B 8615 based on the reference piping. The reference piping consists of 5 m of main piping and 2.5 m of branch piping connected with 0 m height.

Note 2 : The sound level are measured in an anechoic chamber in accordance with JIS B 8616.

Normally, the values measured in the actual operating environment become larger than the indicated values due to the effects of external sound.

Note : Rated conditions Cooling : Indoor air temperature 27°C DB/19°C WB, Outdoor air temperature 35°C DB

Heating : Indoor air temperature 20°C DB, Outdoor air temperature 7°C DB/6°C WB

**MMU-AP0074HP-E to AP0564HP-E**

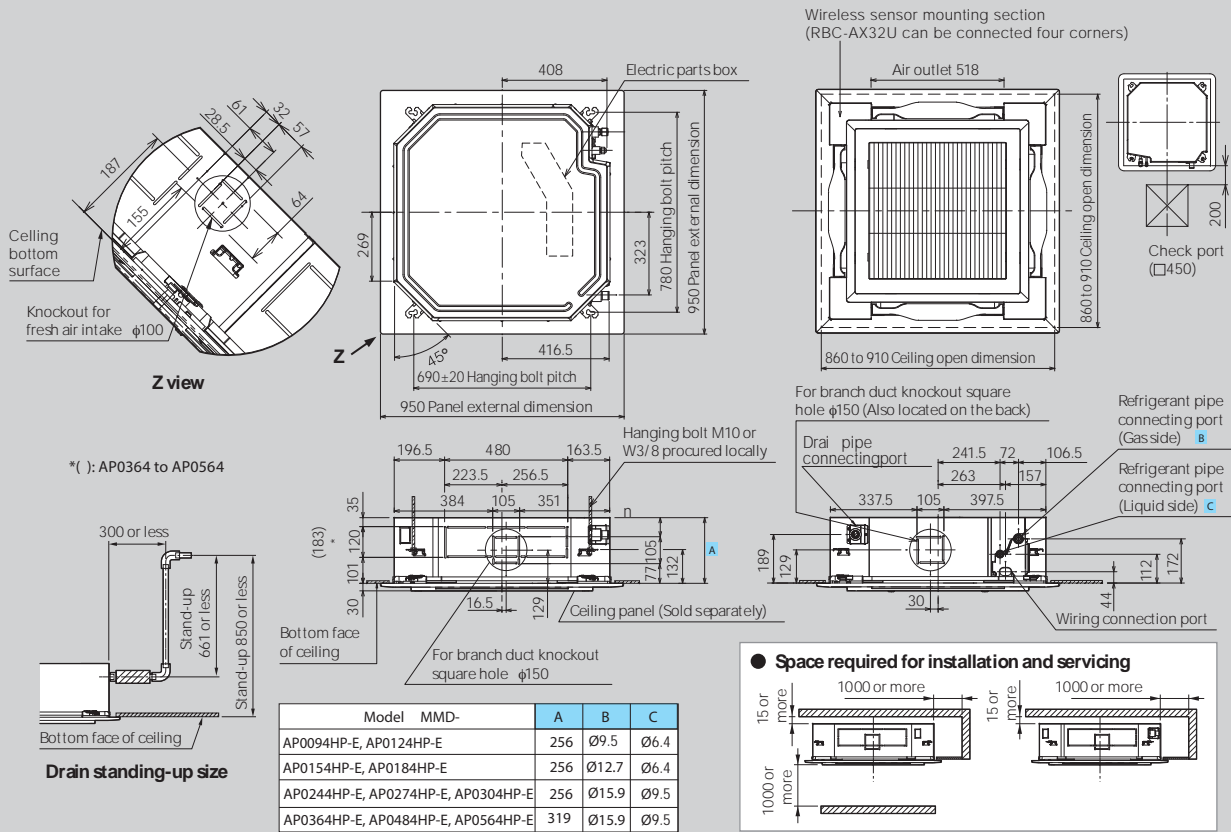

\* The figure shows the RBC-U31PG(W)-E panel.

(Unit: mm)

**Options**

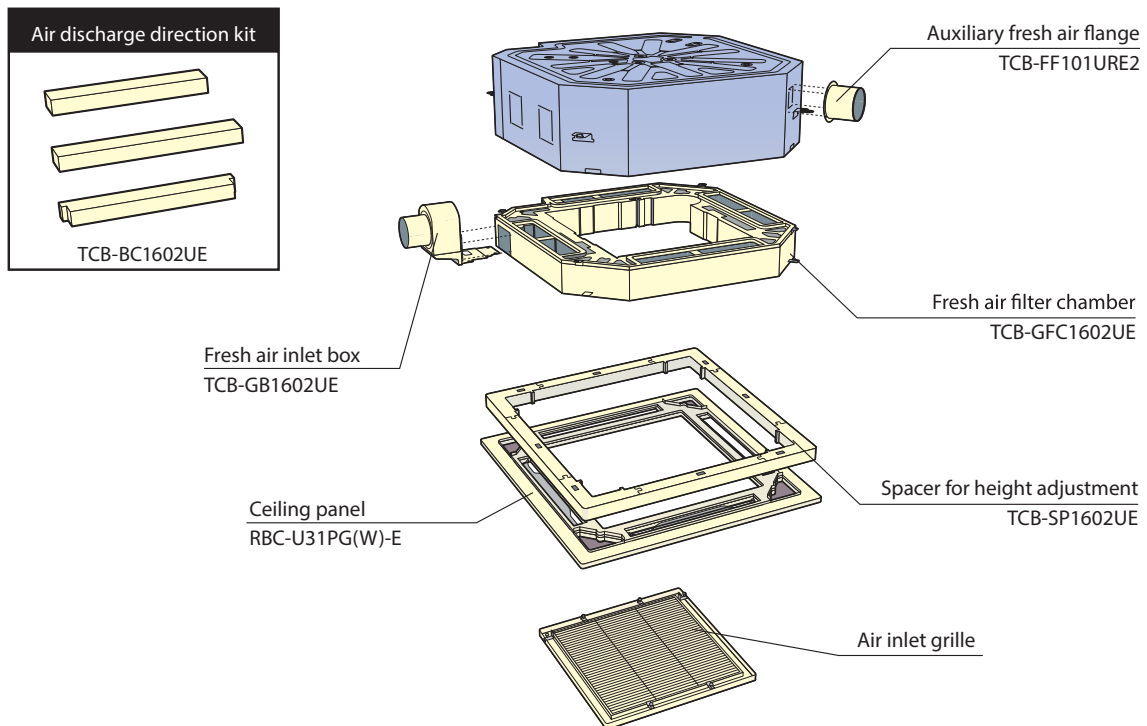

## Compact 4-way Cassette (600 × 600) Type

MMU-AP\*\*\*4MH-E

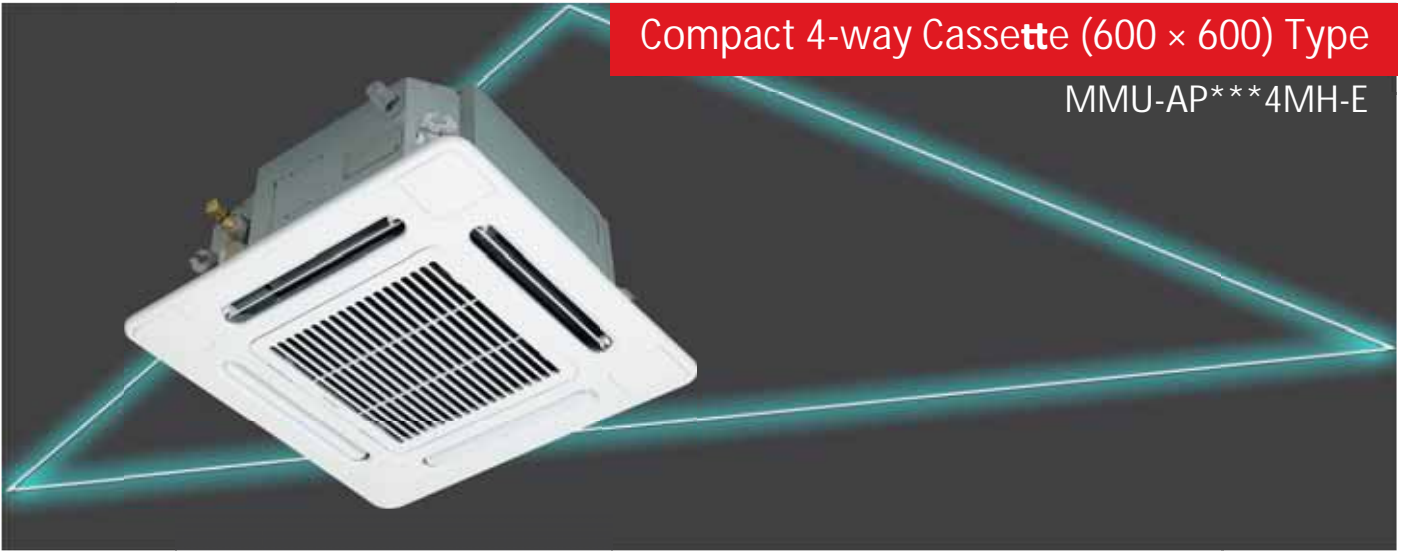

### Perfect for grid system ceiling

This compact unit (575 × 575 mm) fits perfectly into ceilings and matches standard architectural modules, without the need to cut ceiling tiles. The flaps fold tightly against the ceiling when operation stops so that the ceiling is affected only slightly even if air conditioning is installed.



RBC-UM11PG(W)E

### Designed for simple & easy installation and maintenance

The slim design is only 268 mm in height even when an electrical box is located inside the unit. Easy installation is also possible using the panel adjust pocket. Use the "adjust pocket" function for fine adjustments after installation. Available for ceilings up to 3.5 m in height. The drain-checking hole makes it possible to check the drain pan through the side case.



Drain-checking hole

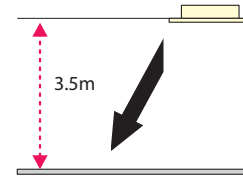

Maximum height

### Technical specifications

Model name		MMU-	AP0074MH-E	AP0094MH-E	AP0124MH-E	AP0154MH-E	AP0184MH-E
Cooling/Capacity*1		(kW)	2.2	2.8	3.6	4.5	5.6
Electrical characteristics	Power requirements	1-phase 50Hz 230V (220–240V) (Separate power supply for indoor units required.)					
	Power consumption 50 Hz/	(kW)	0.034	0.036	0.038	0.041	0.052
Appearance (Ceiling panel)		Model	RBC-UM11PG(W)-E				
External dimensions: Main unit (Ceiling panel)*	Height	(mm)	268 (27)*				
	Width	(mm)	575 (700)*				
	Depth	(mm)	575(700)*				
Total weight: Main unit (Ceiling panel)*		(kg)	17 (3)*				
Fan unit	Standard air flow (High/Mid/Low)	(m <sup>3</sup> /h)	552/462/378	570/468/378	594/504/402	660/552/468	762/642/522
	Motor output	(W)	60				
Connecting pipe	Gas side	(mm)	ø9.5			ø12.7	
	Liquid side	(mm)	ø6.4				
	Drain port	(nominal dia.)	25 (Polyvinyl chloride tube)				
Sound pressure level*2 (High/Mid/Low)		(dB(A))	36/32/28	37/33/28	37/33/29	40/35/30	44/39/34

\* Figures in parentheses are for ceiling panels.

Note 1 : The capacities are measured under the conditions specified by JIS B 8615 based on the reference piping.

The reference piping consists of 5 m of main piping and 2.5 m of branch piping connected with 0 m height.

Note 2 : The sound level are measured in an anechoic chamber in accordance with JIS B 8616.

Normally, the values measured in the actual operating environment become larger than the indicated values due to the effects of external sound.

Note : Rated conditions Cooling : Indoor air temperature 27°C DB/19°C WB, Outdoor air temperature 35°C DB

Heating : Indoor air temperature 20°C DB, Outdoor air temperature 7°C DB/6°C WB

**MMU-AP0074MH-E to AP0184MH-E**

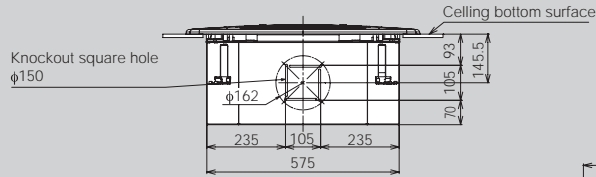

Model	MMD-	A
AP0074MH-E, AP0094MH-E, AP0124MH-E		Ø 9.5
AP0154MH-E, AP0184MH-E		Ø12.7

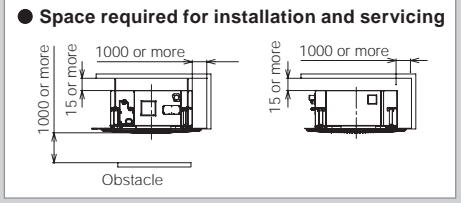
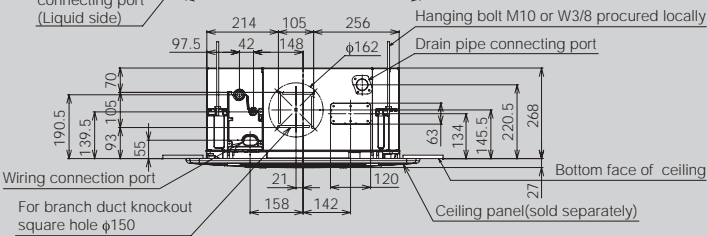
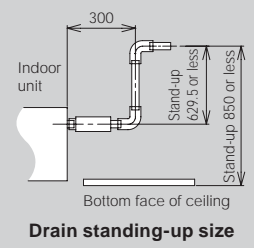
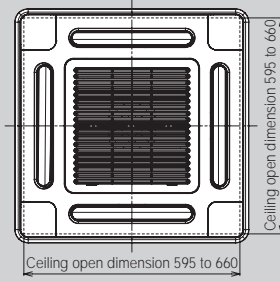
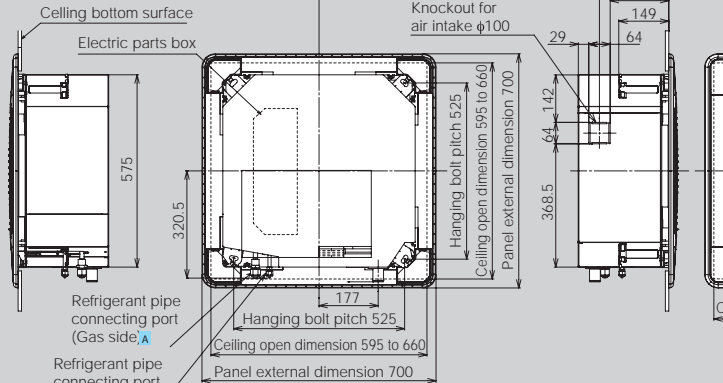
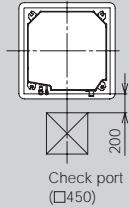

(Unit: mm)

**Options**

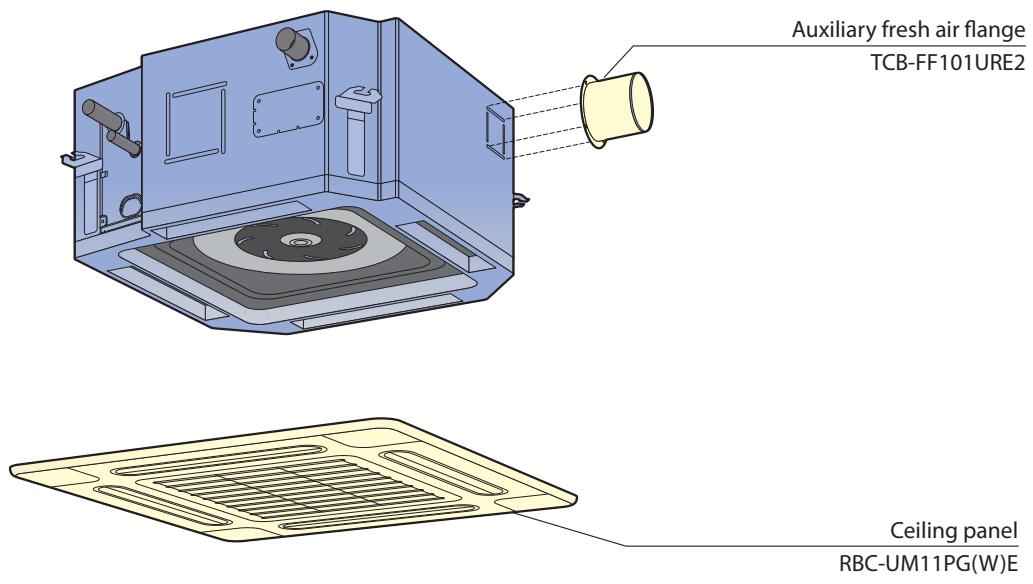



**2-way Air Discharge Cassette Type**

MMU-AP\*\*\*2WH

**Slim and compact unit**

Unified the width of ceiling panel to 680mm.

Condensate drain pump included.

Available for ceilings up to 3.8m in height. (in case of 0.8HP to 3.2HP)

Easy installation and fine adjustment using the “Adjust-Cover” function.

**Technical specifications**

Model name	MMU-	AP0072WH	AP0092WH	AP0122WH	AP0152WH	AP0182WH	AP0242WH	AP0272WH	AP0302WH	AP0362WH	AP0482WH	AP0562WH	
Cooling/Capacity* <sup>1</sup>	(kW)	2.2	2.8	3.6	4.5	5.6	7.1	8.0	9.0	11.2	14.0	16.0	
Electrical characteristics	Power requirements	1-phase 50Hz 230V (220–240V) (Separate power supply for indoor units required.)											
	Power consumption 50 Hz (kW)		0.029		0.030	0.044	0.054	0.064	0.076	0.088	0.117		
Appearance (Ceiling panel)	Model	RBC-UW283PG(W)-E				RBC-UW803PG(W)-E				RBC-UW1403(W)PG-E			
External dimensions: Main unit (Ceiling panel)*	Height (mm)	295 (20)				345 (20)							
	Width (mm)	815 (1050)				1180 (1415)				1600 (1835)			
	Depth (mm)	570 (680)											
Total weight: Main unit (Ceiling panel)*	(kg)	19 (10)				26 (14)				36 (14)			
Fan unit	Standard air flow (High/Mid/Low) (m <sup>3</sup> /h)	558/498/450			600/534/450	900/750/618	1050/840/738		1260/900/780	1740/1434/1182	1800/1482/1230	2040/1578/1320	
	Motor output (W)	20				30	40		50	70			
Connecting pipe	Gas side (mm)	ø9.5			ø12.7		ø15.9						
	Liquid side (mm)	ø6.4				ø9.5							
	Drain port (nominal dia.)	25 (Polyvinyl chloride tube)											
Sound pressure level* <sup>2</sup> (High/Mid/Low)	(dB(A))	34/32/30			35/33/30		38/35/33		40/37/34	42/39/36	43/40/37	46/42/39	

\* Figures in parentheses are for ceiling panels.

Note 1 : The capacities are measured under the conditions specified by JIS B 8615 based on the reference piping. The reference piping consists of 5 m of main piping and 2.5 m of branch piping connected with 0 m height.

Note 2 : The sound level are measured in an anechoic chamber in accordance with JIS B 8616.

Normally, the values measured in the actual operating environment become larger than the indicated values due to the effects of external sound.

Note : Rated conditions Cooling : Indoor air temperature 27°C DB/19°C WB, Outdoor air temperature 35°C DB

Heating : Indoor air temperature 20°C DB, Outdoor air temperature 7°C DB/6°C WB

**MMU-AP0072WH to AP0152WH**

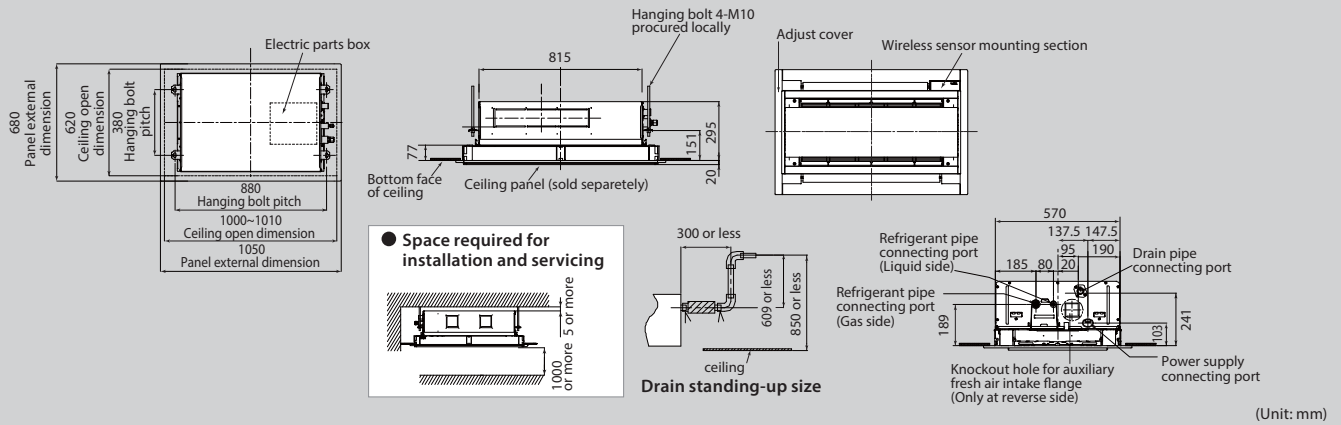

**MMU-AP0182WH to AP0302WH**

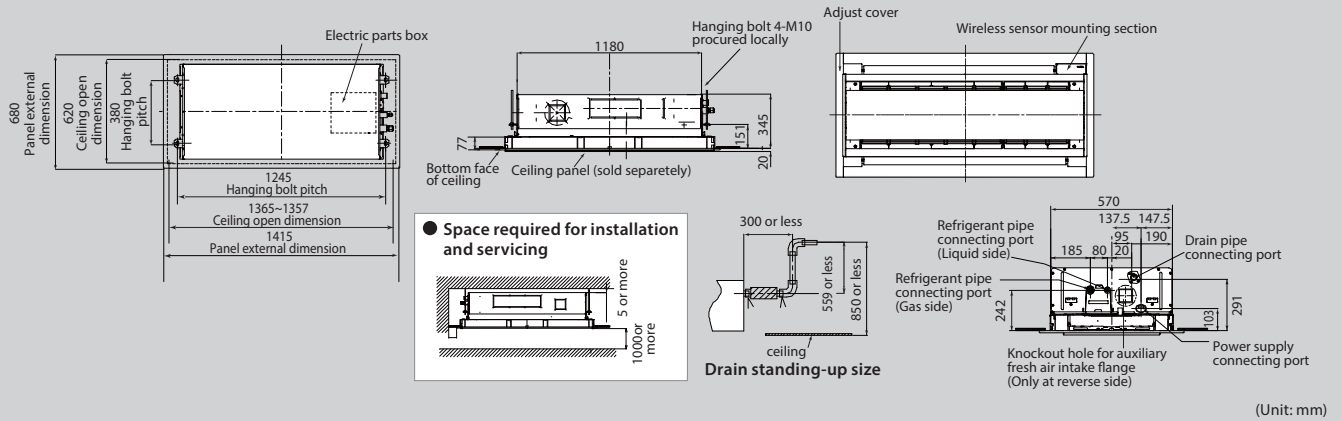

**MMU-AP0362WH to AP0562WH**

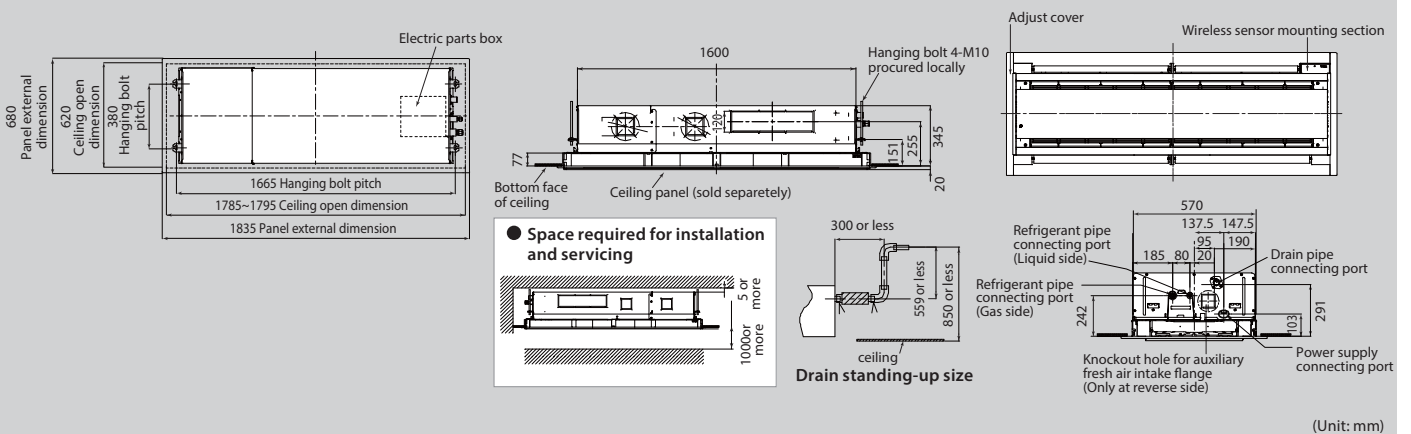

**Options**

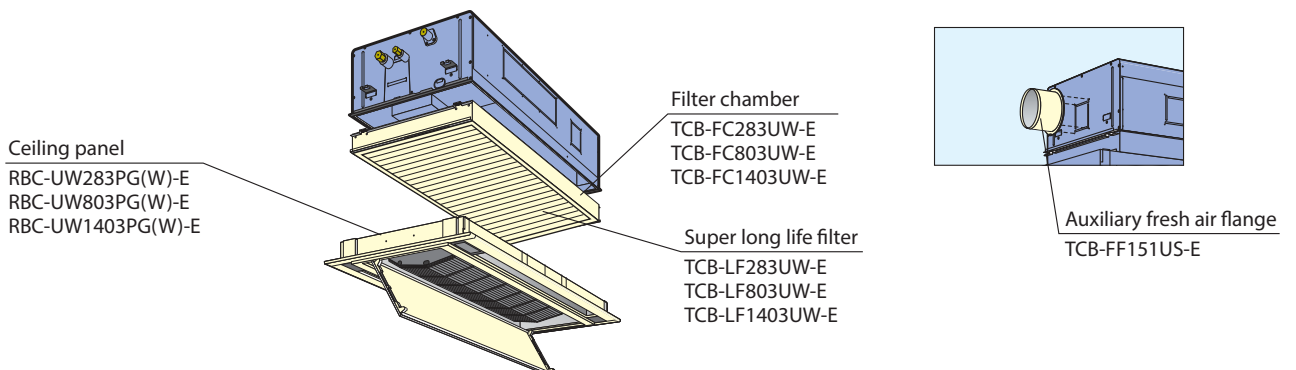

**1-way Air Discharge Cassette Type**

MMU-AP\*\*\*4YH-E  
MMU-AP\*\*\*4SH-E



The perfect choice for hotels and reception areas

Fresh air intake is possible (MMU-AP\*\*\*4SH-E)

Silent sound design ensures the quiet required for the office.

Preparations/connection possible with a circle duct flange.

Ideal for smaller rooms where one-way air distribution is required.

Able to blow air straight out.

Condensate drain pump included.

Long-life filters fitted as standard.

**Technical specifications**

Model name		MMU-	AP0074YH-E	AP0094YH-E	AP0124YH-E	AP0154SH-E	AP0184SH-E	AP0244SH-E	
Cooling/Capacity *1		(kW)	2.2	2.8	3.6	4.5	5.6	7.1	
Electrical characteristics	Power requirements	1-phase 50Hz 230V (220–240V) (Separate power supply for indoor units required.)							
	Power consumption 50 Hz/60 Hz (kW)		0.053			0.042	0.046	0.075	
Appearance (Ceiling panel)		Model	RBC-UY136PG			RBC-US21PGE			
External dimensions: Main unit (Ceiling panel)*	Height (mm)		235 (18)*			200 (20)*			
	Width (mm)		850 (1050)*			1000 (1230)*			
	Depth (mm)		400 (470)*			710 (800)*			
Total weight: Main unit (Ceiling panel)*		(kg)	22 (3.5)*			21 (5.5)*		22 (5.5)*	
Fan unit	Standard air flow (High/Mid/Low) (m <sup>3</sup> /h)		540/480/420			750/690/630	780/720/660		1140/960/810
	Motor output (W)		22			30			
Connecting pipe	Gas side (mm)		ø9.5			ø12.7		ø15.9	
	Liquid side (mm)		ø6.4					ø9.5	
	Drain port (nominal dia.)		25 (Polyvinyl chloride tube)						
Sound pressure level*2 (High/Mid/Low) (dB(A))			42/39/34			37/35/32	38/36/34		45/41/37

\* Figures in parentheses are for ceiling panels.

Note 1 : The capacities are measured under the conditions specified by JIS B 8615 based on the reference piping. The reference piping consists of 5 m of main piping and 2.5 m of branch piping connected with 0 m height.

Note 2 : The sound level are measured in an anechoic chamber in accordance with JIS B 8616.

Normally, the values measured in the actual operating environment become larger than the indicated values due to the effects of external sound.

Note : Rated conditions Cooling : Indoor air temperature 27°C DB/19°C WB, Outdoor air temperature 35°C DB Heating : Indoor air temperature 20°C DB, Outdoor air temperature 7°C DB/6°C WB

**MMU-AP0074YH-E to AP0124YH-E**

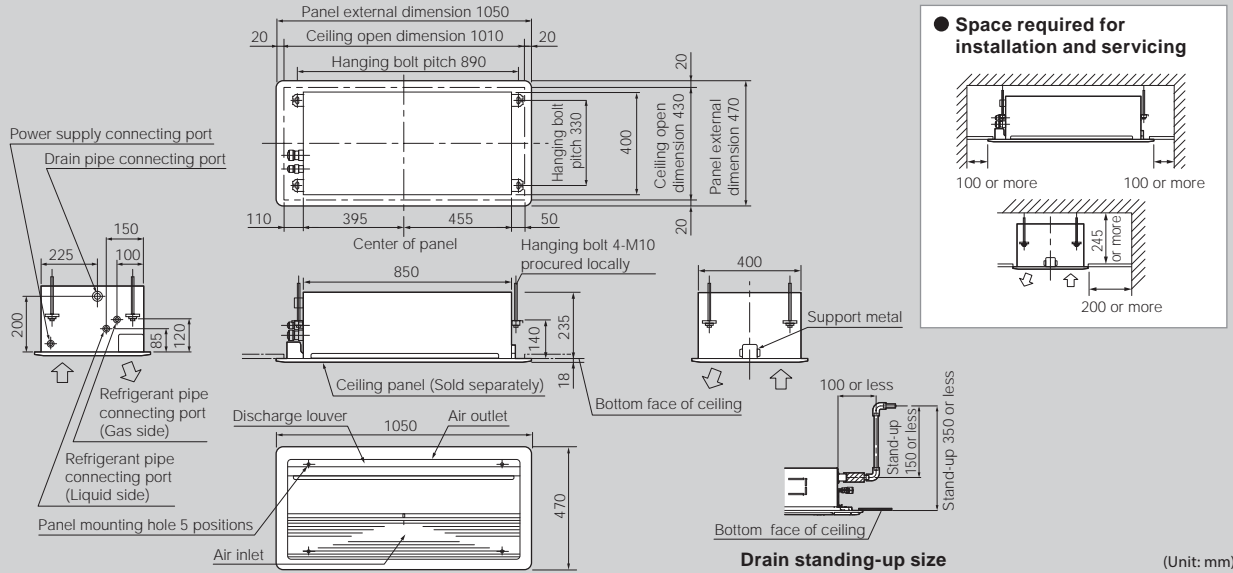

**MMU-AP0154SH-E to AP0244SH-E**

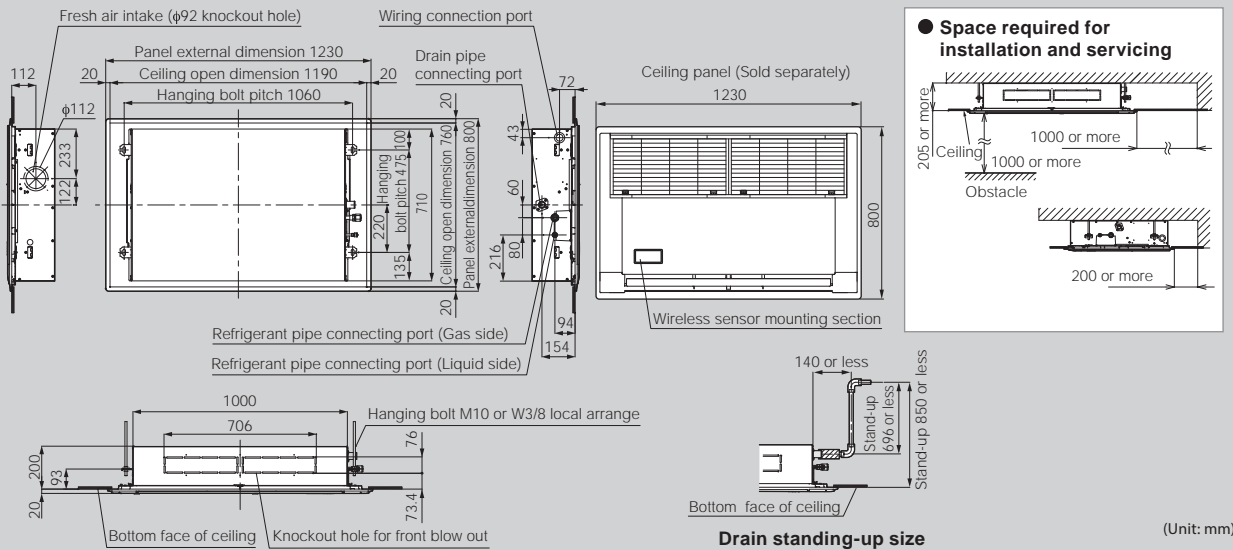

**Options**

**AP0074YH-E/AP0094YH-E/AP0124YH-E**

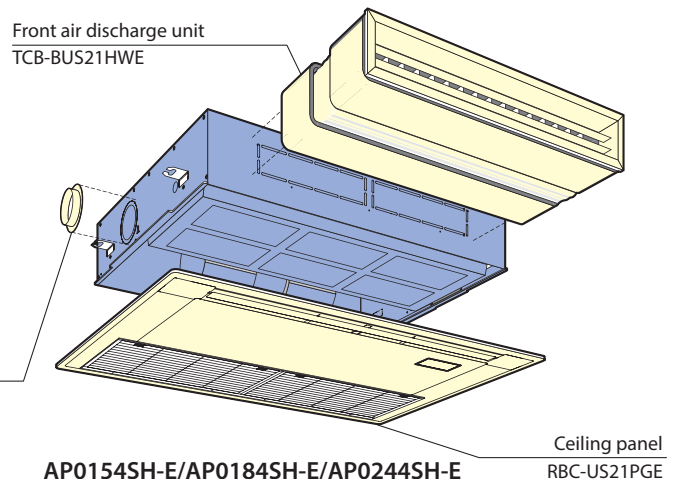
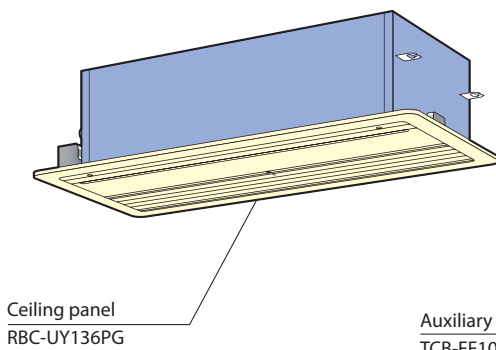

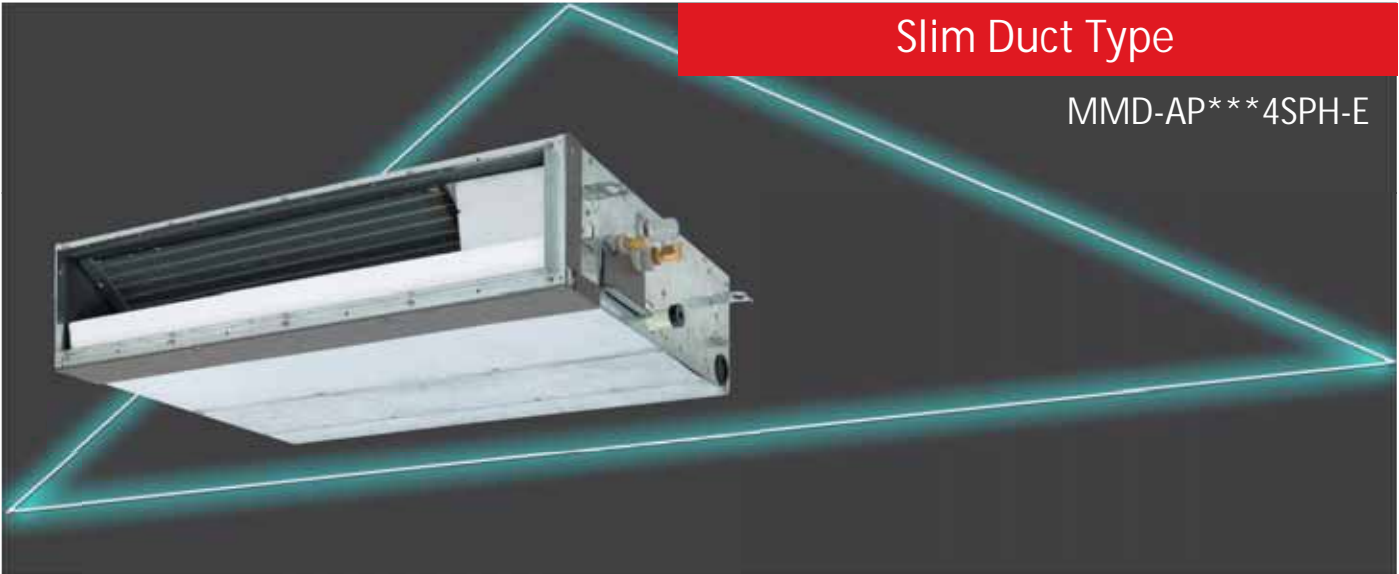

## Slim Duct Type

MMD-AP\*\*\*4SPH-E

### Functional design

Only 210 mm in height for greater application flexibility.

4-step static pressure setup.

Concealed installation within a ceiling void.

Auxiliary fresh air intake available.

### Slim & quiet

Perfect comfort throughout the room.

Can be used with any style of air diffuser.

Quiet, powerful operation.

## Technical specifications

Model name		MMD-	AP0074SPH-E	AP0094SPH-E	AP0124SPH-E	AP0154SPH-E	AP0184SPH-E	AP0244SPH-E	AP0274SPH-E	
Cooling/Capacity*1		(kW)	2.2	2.8	3.6	4.5	5.6	7.1	8.0	
Electrical characteristics	Power supply	1-phase 50Hz 230V (220-240V) (Separate power supply for indoor units required.)								
	Power consumption 50 Hz/60 Hz	(kW)	0.039		0.043	0.045	0.054		0.105	
External dimensions	Height	(mm)	210							
	Width	(mm)	845					1140		
	Depth	(mm)	645							
Total weight		(kg)	22			23		29		
Fan unit	Standard air flow (High/Mid/Low)	(m <sup>3</sup> /h)	540/470/400		600/520/450	690/600/520	780/680/580	1080/1000/900		
	Motor output	(W)	60						120	
	External static pressure	(Pa)	6-16-31-46 (4 steps)		5-15-30-45 (4 steps)		4-14-29-44 (4 steps)	2-12-22-42 (4 steps)		
Connecting pipe	Gas side	(mm)	ø9.5			ø12.7		ø15.9		
	Liquid side	(mm)	ø6.4						ø9.5	
	Drain port	(nominal dia.)	25 (Polyvinyl chloride tube)							
Sound pressure level*2 (High/Med./Low)	Under air inlet	(dB(A))	36/33/30		38/35/32	39/36/33	40/38/36	49/47/44		
	Back air inlet	(dB(A))	28/26/24		29/27/25	32/30/28	33/31/29	38/36/33		

Note 1 : The capacities are measured under the conditions specified by JIS B 8615 based on the reference piping.

The reference piping consists of 5 m of main piping and 2.5 m of branch piping connected with 0 m height.

Note 2 : The sound level are measured in an anechoic chamber in accordance with JIS B 8616.

Normally, the values measured in the actual operating environment become larger than the indicated values due to the effects of external sound.

Note : Rated conditions Cooling : Indoor air temperature 27°C DB/19°C WB, Outdoor air temperature 35°C DB

Heating : Indoor air temperature 20°C DB, Outdoor air temperature 7°C DB/6°C WB



**Concealed Duct High Static Pressure Type**

**MMD-AP\*\*\*6HP-E**

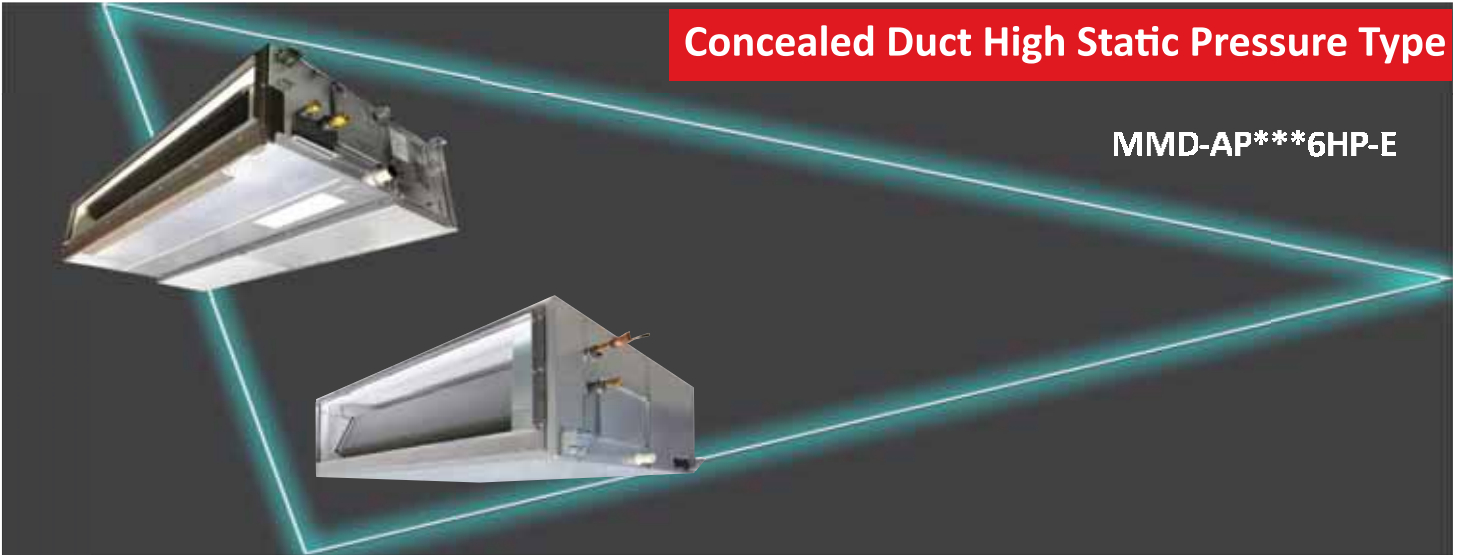

**Design flexibility**

Satisfies all your design needs.  
Compatible with external static pressures up to 200 Pa. (up to 16.0 kW) and 250 Pa (for 22.4 & 28.0kW)

Can be equipped with the following options:

- high-efficiency filter (65, 90)
- drain pump kit

**Construction characteristics**

Three-stage-switchable static pressure.  
The flexible duct is accessible.  
Easy service and installation.  
Inspection hole enables easy access and maintenance.

**Technical specifications**

Model name		MMD-	AP0186HP-E	AP0246HP-E	AP0276HP-E	AP0366HP-E	AP0486HP-E	AP0566HP-E	AP0726HP-E	AP0966HP-E	
Cooling capacity*1		(kW)	5.6	7.1	8.0	11.2	14.0	16.0	22.4	28.0	
Electrical characteristics	Power requirements	1-phase 50Hz 230V (220-240V) / 1-phase 60Hz 220V (Separate power supply for indoor units required.)									
	Power consumption 50 Hz/60 Hz	(kW)	0.085	0.115		0.198	0.230	0.290	0.540	0.790	
External dimensions	Height	(mm)	298						448		
	Width	(mm)	1,000			1,400			1,400		
	Depth	(mm)	750						900		
Total weight		(kg)	34			43			97		
Fan unit	Standard air flow (Med./Low)	(m³/h)	800 (660/550)	1,200 (970/800)		1,920 (1,560/1,340)	2,100 (1,740/1,420)	2,400 (2,040/1,660)	3,800 (3,200/2,500)	4,800 (4,200/3,500)	
	Motor output	(W)	250			350			250		
	External static pressure (factory setting)	(Pa)	100						150		
	External static pressure	(Pa)	50-75-125-150-175-200 (7steps)						50-83-117-150-183-217-250 (7steps)		
Connecting pipe	Gas side	(mm)	ø12.7	ø15.9			ø22.2				
	Liquid side	(mm)	ø6.4	ø9.5			ø12.7				
	Drain port (nominal dia.)		25 (Polyvinyl chloride tube)						25 (Polyvinyl chloride tube)		
Sound pressure level*2 (High/Mid/Low)		(dB(A))	37 (32/30)	38 (34/31)		41 (37/34)	42 (40/35)	45 (42/37)	44 (40/36)	46 (42/38)	

Note 1 : The cooling capacities and electrical characteristics are measured under the conditions specified by JIS B 8615 based on the reference piping.  
The reference piping consists of 5m of main piping and 2.5 of branch piping connected with 0 meter height.

Note 2 : The sound level are measured in an anechoic chamber in accordance with JIS B 8616.

Normally, the values measured in the actual operating environment become larger than the indicated values due to the effects of external sound.

Note : Rated conditions Cooling : Indoor air temperature 27°C DB/19°C WB, Outdoor air temperature 35°C DB



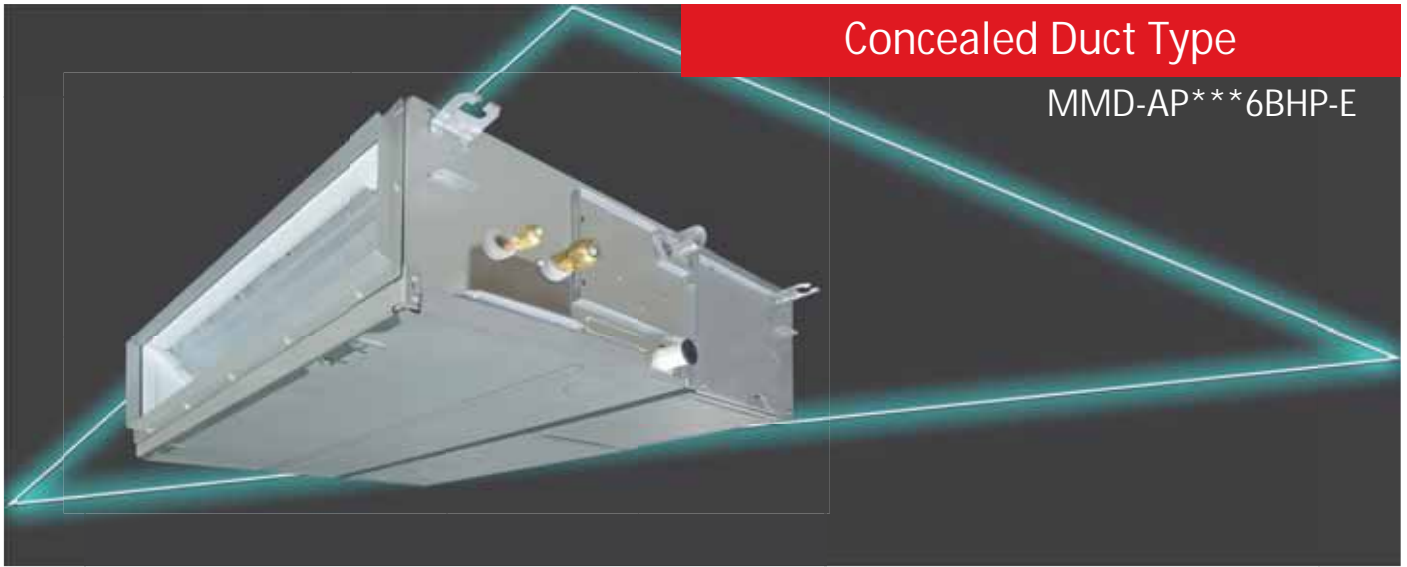

## Concealed Duct Type

MMD-AP\*\*\*6BHP-E

### High static pressure

External static pressure can be raised as high as 120 Pa, so that all areas of the room can be reached for even temperature distribution, no matter how complex the layout.

### High-lift drain pump

Built-in high-lift drain pump up to 850 mm.

## Technical specifications

Model name		MMD-	AP0076BHP-E	AP0096BHP-E	AP0126BHP-E	AP0156BHP-E	AP0186BHP-E	AP0246BHP-E	AP0276BHP-E	AP0306BHP-E	AP0366BHP-E	AP0486BHP-E	AP0566BHP-E
Cooling/Capacity* <sup>1</sup>		(kW)	2.2	2.8	3.6	4.5	5.6	7.1	8.0	9.0	11.2	14.0	16.0
Electrical characteristics	Power requirements	1-phase 50Hz 230V (220–240V) / 1-phase 60Hz 220V (Separate power supply for indoor units required.)											
	Power consumption 50 Hz (kW)	0.038	0.043	0.062	0.077	0.094	0.172	0.198					
External dimension	Height (mm)	275											
	Width (mm)	700			700			1,000			1,400		
	Depth (mm)	750											
Total weight (kg)		23				30				40			
Fan unit	Standard air flow (Mid/Low) (m <sup>3</sup> /h)	540/450/360	570/480/390	798/660/540	1,200/990/870			1,260/1,110/930	1,920/1,620/1,380	2,100/1,740/1,500			
	Motor output (W)	150									250		
	External static pressure (factory setting) (Pa)	30						40			50		
	External static pressure (Pa)	30-40-50-65-80-100-120 (7 steps)											
Connecting pipe	Gas side (mm)	ø9.5				ø12.7			ø15.9				
	Liquid side (mm)	ø6.4						ø9.5					
	Drain port (nominal dia.)	25 (Polypropylene tube)											
Sound pressure level* <sup>2</sup> (High/Mid/Low) (dB(A))		29/26/23	30/26/23	33/29/25	36/31/27			40/36/33					

Note 1 : The capacities are measured under the conditions specified by JIS B 8615 based on the reference piping.

The reference piping consists of 5 m of main piping and 2.5 m of branch piping connected with 0 m height.

Note 2 : The sound level are measured in an anechoic chamber in accordance with JIS B 8616.

Normally, the values measured in the actual operating environment become larger than the indicated values due to the effects of external sound.

Note : Rated conditions Cooling : Indoor air temperature 27°C DB/19°C WB, Outdoor air temperature 35°C DB

Heating : Indoor air temperature 20°C DB, Outdoor air temperature 7°C DB/6°C WB

**MMD-AP0076BHP-E to AP0566BHP-E**

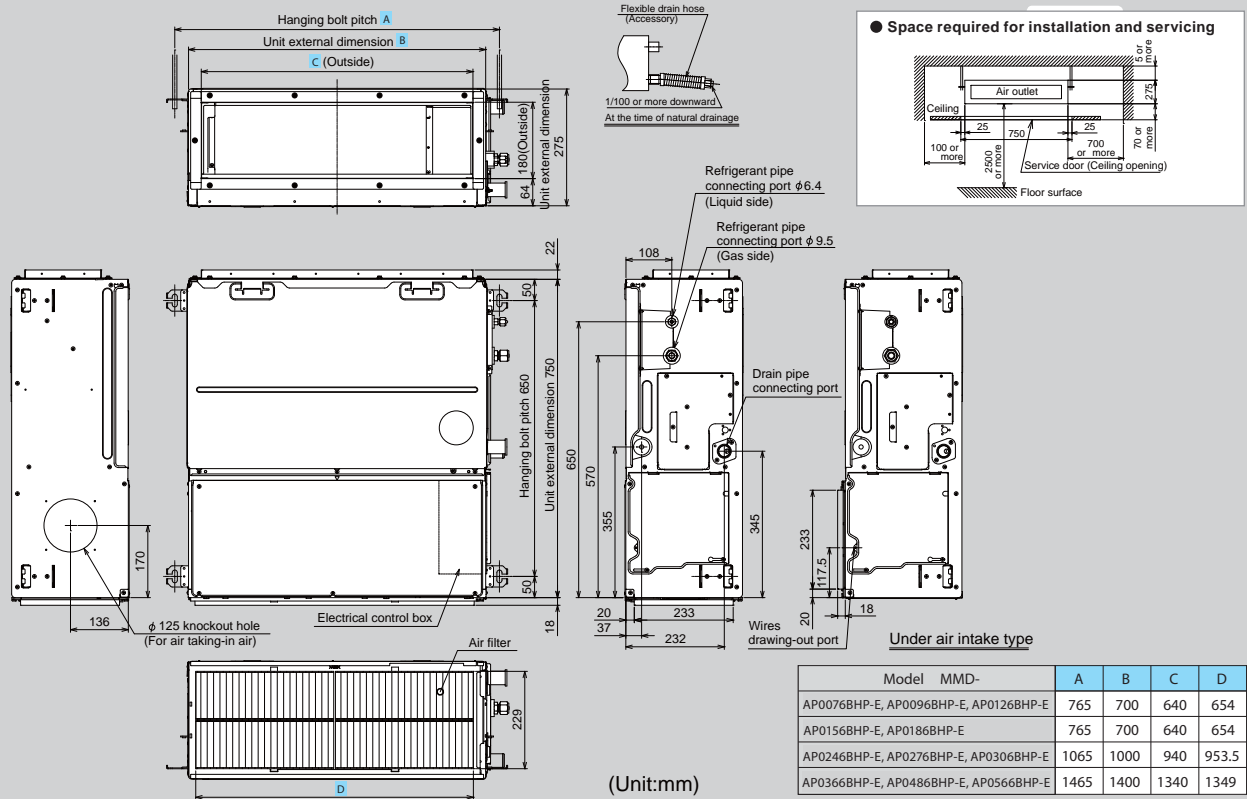

\* Standard filter is provided, but deeper filtration filter needs to be purchased locally.

**Options**

Spigot shaped flange

- TCB-SF56C6BPE
- TCB-SF80C6BPE
- TCB-SF160C6BPE

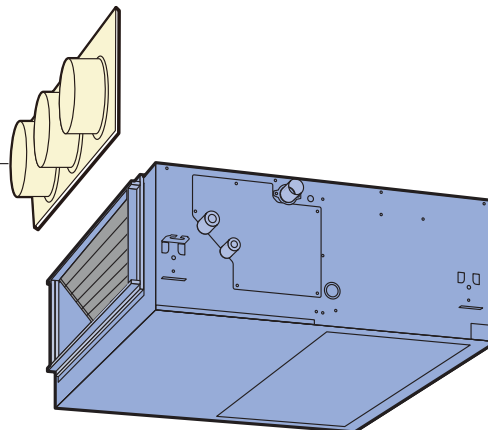

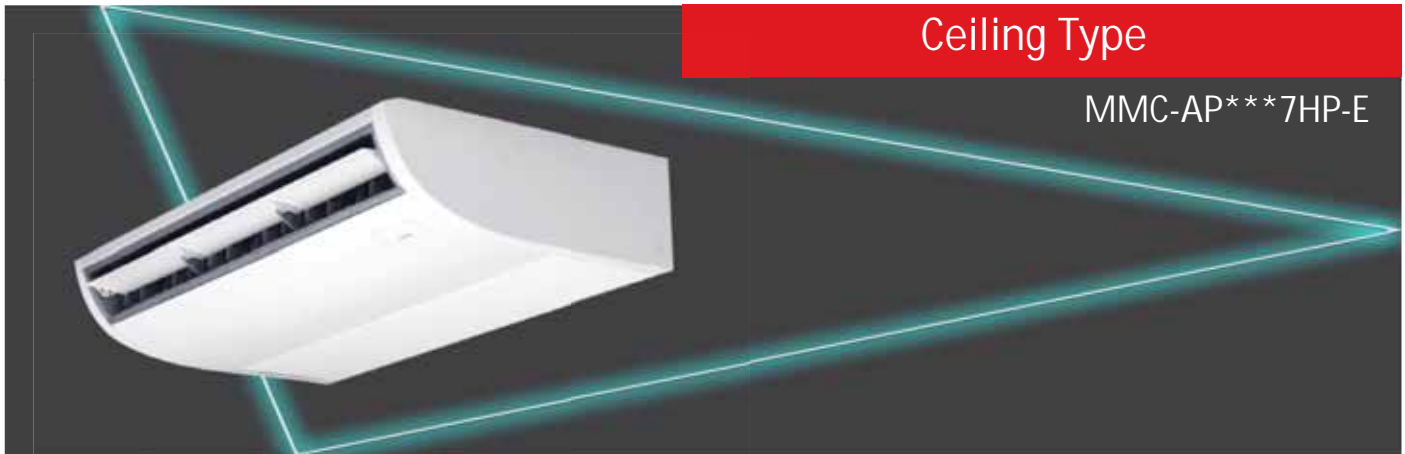

## Ceiling Type

MMC-AP\*\*\*7HP-E

### Smooth curve for pliant Shape

All-new chassis and new rounded design, This new models have been developed in response to customers' needs for ceiling units that better match their room interiors.

### Smooth curve for pliant Shape

New fan has adopted the turbulence prevention rib to optimize the ventilating way. Air volume has increased and noise level also has decreased compared with previous model. Winds of new ceiling type of 4HP to 6HP can be reached up to 4.3 metre.

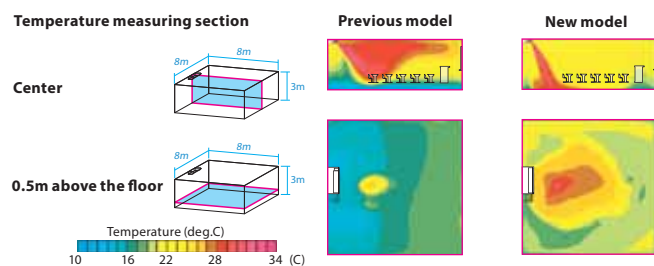

### New Designed Wide Flap

The new air outlet has realized both High noise reduction and large air volume.

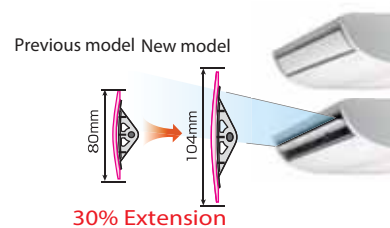

### Flap control

The airflow angle is automatically set to the most suitable setting according to your cooling or heating needs, and an automatic swing mode enables airflow to reach all areas of the room to create a comfortable ambience.

## Technical specifications

Model name	MMC-	AP0157HP-E	AP0187HP-E	AP0247HP-E	AP0277HP-E	AP0367HP-E	AP0487HP-E	AP0567HP-E
Cooling/Capacity*	<sup>1</sup> (kW)	4.5	5.6	7.1	8.0	11.2	14.0	16.0
Electrical characteristics	Power requirements	1-phase 50Hz 230V (220-240V) / 1-phase 60Hz 220V (Separate power supply for indoor units required.)						
	Power consumption 50 Hz (kW)	0.033	0.034		0.067		0.083	0.111
External dimensions	Height (mm)	235						
	Width (mm)	950		1,269		1,586		
	Depth (mm)	690						
Total weight (kg)		24		30		37		
Fan unit	Standard air flow (High/Mid/Low) (m <sup>3</sup> /h)	840 / 690 / 540	960 / 720 / 540	1440 / 1020 / 750		1860 / 1350 / 1020	1860 / 1530 / 1200	2040 / 1650 / 1260
	Motor (W)	94		94		139		
Connecting pipe	Gas side (mm)	ø12.7		ø15.9				
	Liquid side (mm)	ø6.4		ø9.5				
	Drain port (nominal dia.)	20 (Polyvinyl chloride tube)						
Sound pressure level* <sup>2</sup> (High/Mid/Low) (dB(A))		36/34/28	37/35/28	41/36/29		44/38/32	44/41/35	46/42/36

Note 1 : The capacities are measured under the conditions specified by JIS B 8615 based on the reference piping.

The reference piping consists of 5 m of main piping and 2.5 m of branch piping connected with 0 m height.

Note 2 : The sound level are measured in an anechoic chamber in accordance with JIS B 8616.

Normally, the values measured in the actual operating environment become larger than the indicated values due to the effects of external sound.

Note : Rated conditions Cooling : Indoor air temperature 27°C DB/19°C WB, Outdoor air temperature 35°C DB

Heating : Indoor air temperature 20°C DB, Outdoor air temperature 7°C DB/6°C WB

**MMC-AP0157HP-E to AP0567HP-E**

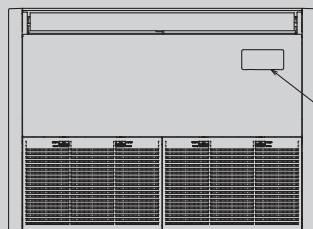
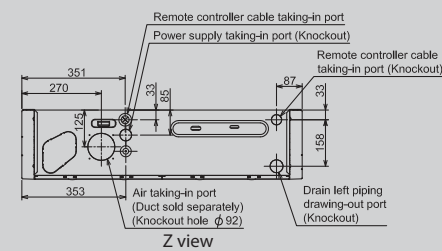
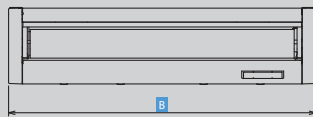
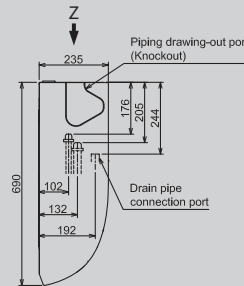
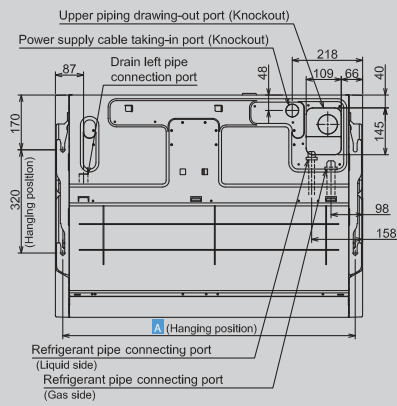

Model	MMC-	A	B
AP0157HP-E, AP0187HP-E		906	950
AP0247HP-E, AP0277HP-E		1223	1269
AP0367HP-E, AP0487HP-E, AP0567HP-E		1540	1586

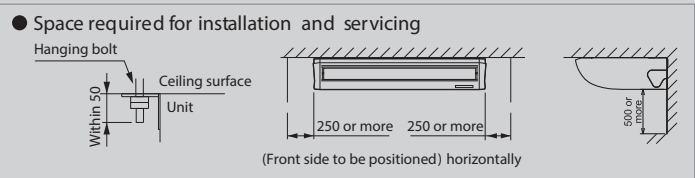

**Options**

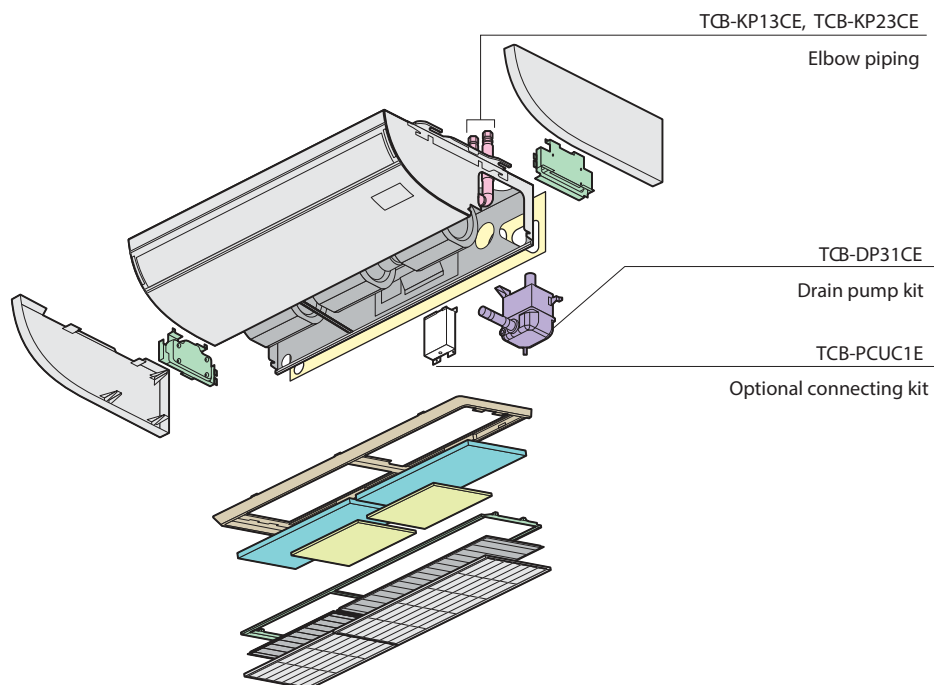



## High-wall Type (3 series)

MMK-AP\*\*\*3H

### Elegant and slim

This classic high-wall is elegant and slim; it can easily blend in with any room interior.

Total comfort is granted, thanks also to the 70° directional auto-swing louver that provides uniform air distribution.



Remote controller

### MMK-AP0073H to AP0243H

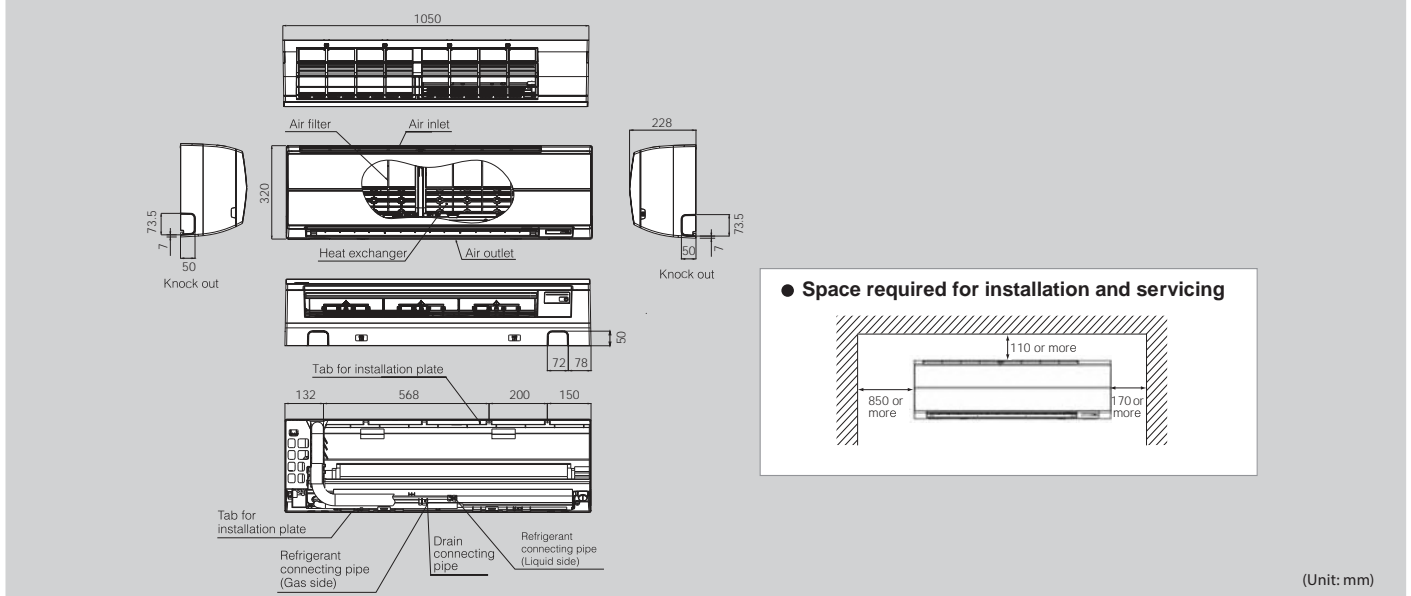

### Technical specifications

Model name	MMK-	AP0073H	AP0093H	AP0123H	AP0153H	AP0183H	AP0243H
Cooling capacity*1	(kW)	2.2	2.8	3.6	4.5	5.6	7.1
Electrical characteristics	Power requirements	1-phase 50Hz 230V (220-240V) (Separate power supply for indoor units required.)					
	Power consumption 50 Hz (kW)	0.018	0.021		0.043		0.050
External dimensions	Height (mm)	320					
	Width (mm)	1050					
	Depth (mm)	228					
Total weight (kg)		15					
Fan unit	Standard air flow (High/Mid/Low) (m <sup>3</sup> /h)	570/450/390	600/480/390		840/660/540		1020/750/570
	Motor output (W)	30					
Connecting pipe	Gas side (mm)	ø9.5		ø12.7		ø15.9	
	Liquid side (mm)	ø6.4					
	Drain port (nominal dia.)	16 (polyvinyl chloride tube)					
Sound pressure level*2 (High/Mid/Low) (dB(A))		35/31/28	37/32/28		41/36/33		46/39/34

Note 1: The capacities are measured under the conditions specified by JIS B 8615 based on the reference piping. The reference piping consists of 5 m of main piping and 2.5 m of branch piping connected with 0 m height.

Note 2: The sound level are measured in an anechoic chamber in accordance with JIS B 8616.

Normally, the values measured in the actual operating environment become larger than the indicated values due to the effects of external sound.

Note: Rated conditions Cooling: Indoor air temperature 27°C DB/19°C WB, Outdoor air temperature 35°C DB

Heating: Indoor air temperature 20°C DB, Outdoor air temperature 7°C DB/6°C WB

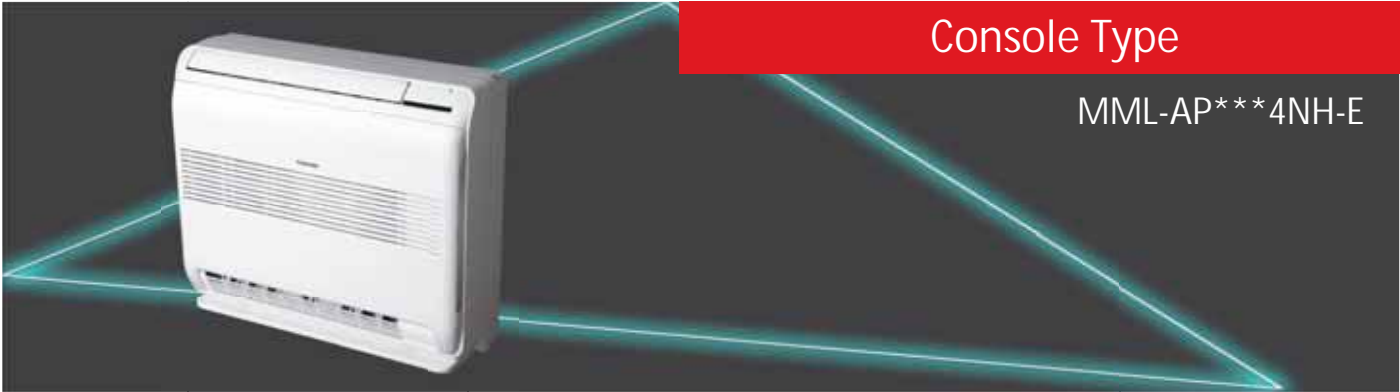

## Console Type

MML-AP\*\*\*4NH-E

### Features

Elegant & simple design makes this unit a perfect fit for shops, office buildings, and luxury apartments. Bottom flow functionality ensures comfortable air bi-flow for an advantage in heating and floor warming. Multi-function operation is convenient, making adjustments by the user possible using the wireless remote controller.



Remote controller

### MML-AP0074NH-E to AP0184NH-E

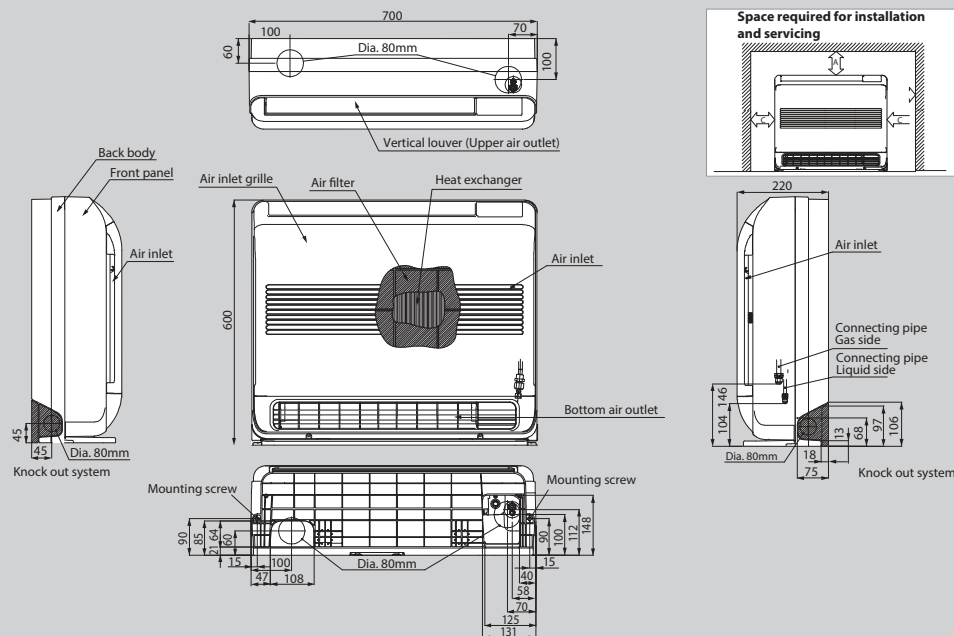

(Unit: mm)

### Technical specifications

Model name	MML-	AP0074NH-E	AP0094NH-E	AP0124NH-E	AP0154NH-E	AP0184NH-E	
Cooling/Capacity*1	(kW)	2.2	2.8	3.6	4.5	5.6	
Electrical characteristics	Power requirements	1-phase 50Hz 230V (220-240V) Separate power supply for indoor units required.)					
	Power consumption 50 Hz	(kW)	0.021		0.025	0.034	0.052
External dimensions	Height	(mm)		600			
	Width	(mm)		700			
	Depth	(mm)			220		
Total weight	(kg)			17			
Fan unit	Standard air flow (High/Mid/Low)	(m <sup>3</sup> /h)	510/366/282		552/408/324	624/468/384	726/528/426
	Motor output	(W)			41		
Connecting pipe	Gas side	(mm)	ø9.5		ø12.7		
	Liquid side	(mm)	ø6.4				
	Drain port	(nominal dia.)	16 (Polyvinyl chloride tube)				
Sound pressure level*2 (High/Mid/Low)	(dB(A))	38/32/26		40/34/29	43/37/31	47/40/34	

Note 1 : The capacities are measured under the conditions specified by JIS B 8615 based on the reference piping. The reference piping consists of 5 m of main piping and 2.5 m of branch piping connected with 0 m height.

Note 2 : The sound level are measured in an anechoic chamber in accordance with JIS B 8616.

Normally, the values measured in the actual operating environment become larger than the indicated values due to the effects of external sound.

Note : Rated conditions Cooling : Indoor air temperature 27°C DB/19°C WB, Outdoor air temperature 35°C DB  
Heating : Indoor air temperature 20°C DB, Outdoor air temperature 7°C DB/6°C WB



## Floor Standing Cabinet Type

MML-AP\*\*\*4H-E

### Slim & compact design

Under-window mounting does not block lighting.

Indoor unit size of 2.2 kW to 7.1 kW is the same.

### Slim & compact design

Distribution can be reversed to suit occupant preference.

Air blown from front panel (factory default)

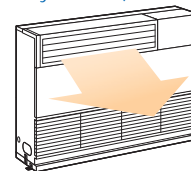

Air blown from top

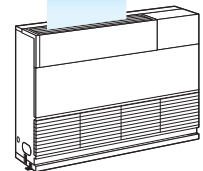

### MML-AP0074H-E to AP0244H-E

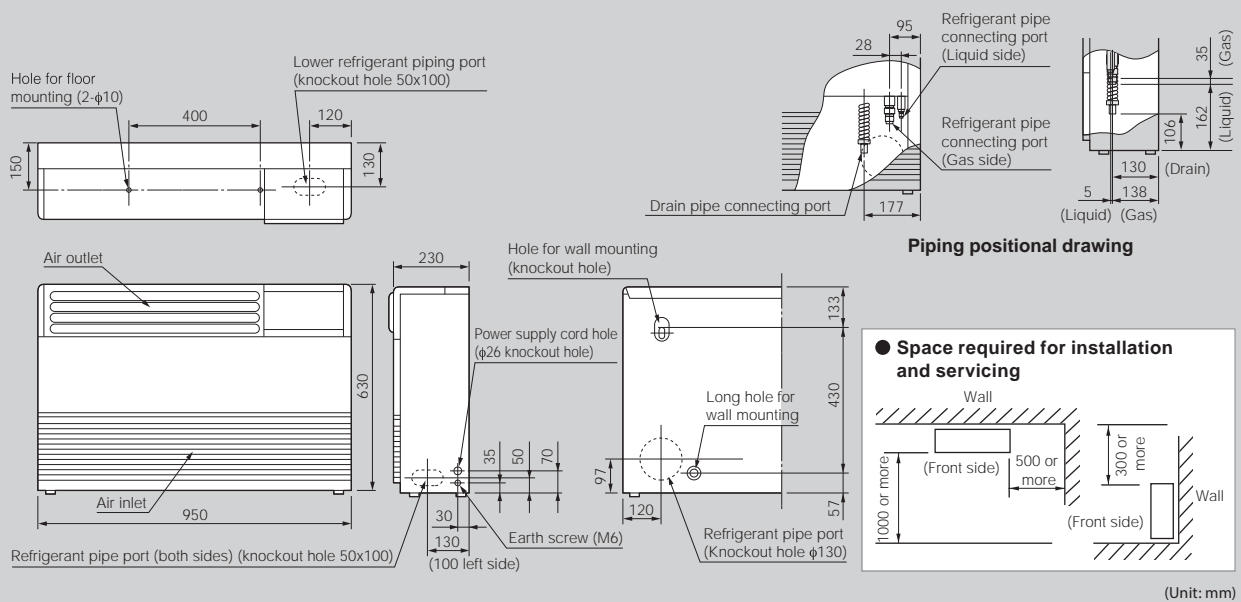

### Technical specifications

Model name	MML-	AP0074H-E	AP0094H-E	AP0124H-E	AP0154H-E	AP0184H-E	AP0244H-E
Cooling/Capacity*1	(kW)	2.2	2.8	3.6	4.5	5.6	7.1
Electrical characteristics	Power requirements	1-phase 50Hz 230V (220-240V) ( Separate power supply for indoor units required.)					
	Power consumption 50 Hz/60 Hz	(kW)	0.056		0.092		0.102
External dimensions	Height	(mm)	630				
	Width	(mm)	950				
	Depth	(mm)	230				
Total weight	(kg)	37				40	
Fan unit	Standard air flow (High/Mid/Low)	(m <sup>3</sup> /h)	480/420/360		900/780/650		1080/930/780
	Motor output	(W)	45				70
Connecting pipe	Gas side	(mm)	ø9.5		ø12.7		ø15.9
	Liquid side	(mm)	ø6.4				ø9.5
	Drain port	(nominal dia.)	20 (Polyvinyl chloride tube)				
Sound pressure level*2 (High/Mid/Low)	(dB(A))	39/37/35			45/41/38		49/44/39

Note 1 : The capacities are measured under the conditions specified by JIS B 8615 based on the reference piping.

The reference piping consists of 5 m of main piping and 2.5 m of branch piping connected with 0 m height.

Note 2 : The sound level are measured in an anechoic chamber in accordance with JIS B 8616.

Normally, the values measured in the actual operating environment become larger than the indicated values due to the effects of external sound.

Note : Rated conditions Cooling : Indoor air temperature 27°C DB/19°C WB, Outdoor air temperature 35°C DB

Heating : Indoor air temperature 20°C DB, Outdoor air temperature 7°C DB/6°C WB



## Floor Standing Concealed Type

MML-AP\*\*\*4BH-E

### Cool air makes for a pleasant indoor environment

Install it under a window and air-condition any room effectively.

### Easy maintenance

Simplified design of fan and drainage pipe eases maintenance.

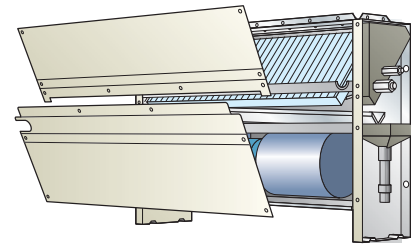

### MML-AP0074BH-E to AP0244BH-E

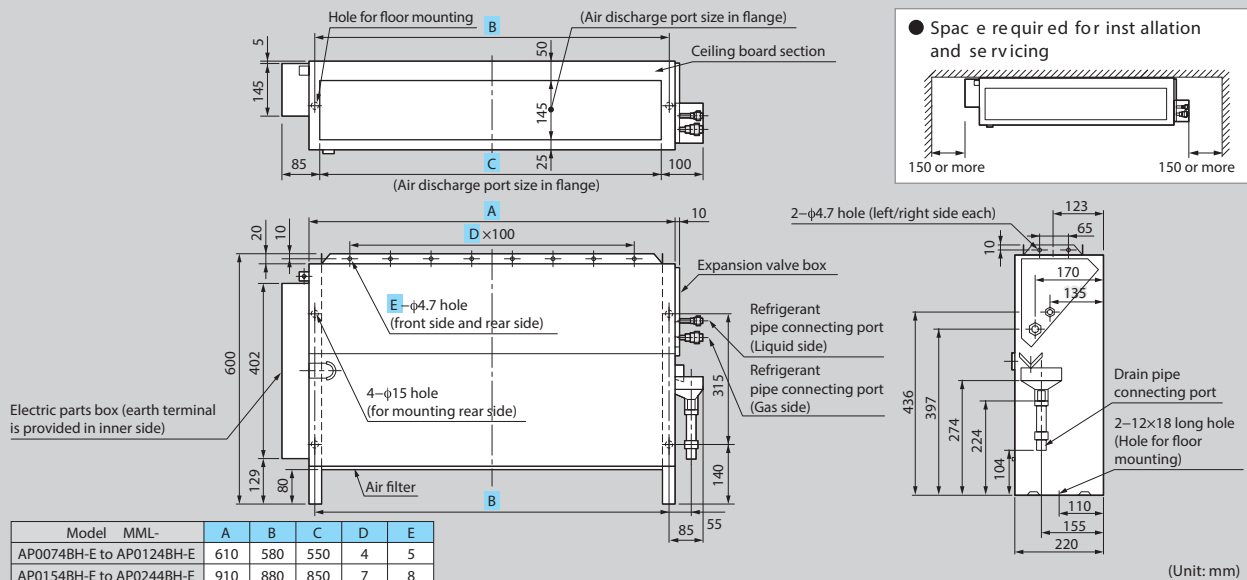

## Technical specifications

Model name		MML-	AP0074BH-E	AP0094BH-E	AP0124BH-E	AP0154BH-E	AP0184BH-E	AP0244BH-E	
Cooling Capacity*1		(kW)	2.2	2.8	3.6	4.5	5.6	7.1	
Electrical characteristics	Power requirements	1-phase 50Hz 230V (220-240V) / 1-phase 60Hz 220V (Separate power supply for indoor units required.)							
	Power consumption 50 Hz	(kW)	0.056			0.090		0.095	
External dimensions	Height	(mm)	600						
	Width	(mm)	745			1045			
	Depth	(mm)	220						
Total weight		(kg)	21			29			
Fan unit	Standard air flow (High/Mid/Low)	(m <sup>3</sup> /h)	460/400/300			740/600/490		950/790/640	
	Motor output	(W)	19			70			
Connecting pipe	Gas side	(mm)	ø9.5		ø12.7		ø15.9		
	Liquid side	(mm)	ø6.4						
	Drain port	(nominal dia.)	20 (Polyvinyl chloride tube)						
Sound pressure level*2 (High/Mid/Low)		(dB(A))	36/34/32			42/37/33			

Note 1: The capacities are measured under the conditions specified by JIS B 8615 based on the reference piping. The reference piping consists of 5 m of main piping and 2.5 m of branch piping connected with 0 m height.

Note 2: The sound level are measured in an anechoic chamber in accordance with JIS B 8616.

Normally, the values measured in the actual operating environment become larger than the indicated values due to the effects of external sound.

Note: Rated conditions Cooling: Indoor air temperature 27°C DB/19°C WB, Outdoor air temperature 35°C DB  
Heating: Indoor air temperature 20°C DB, Outdoor air temperature 7°C DB/6°C WB

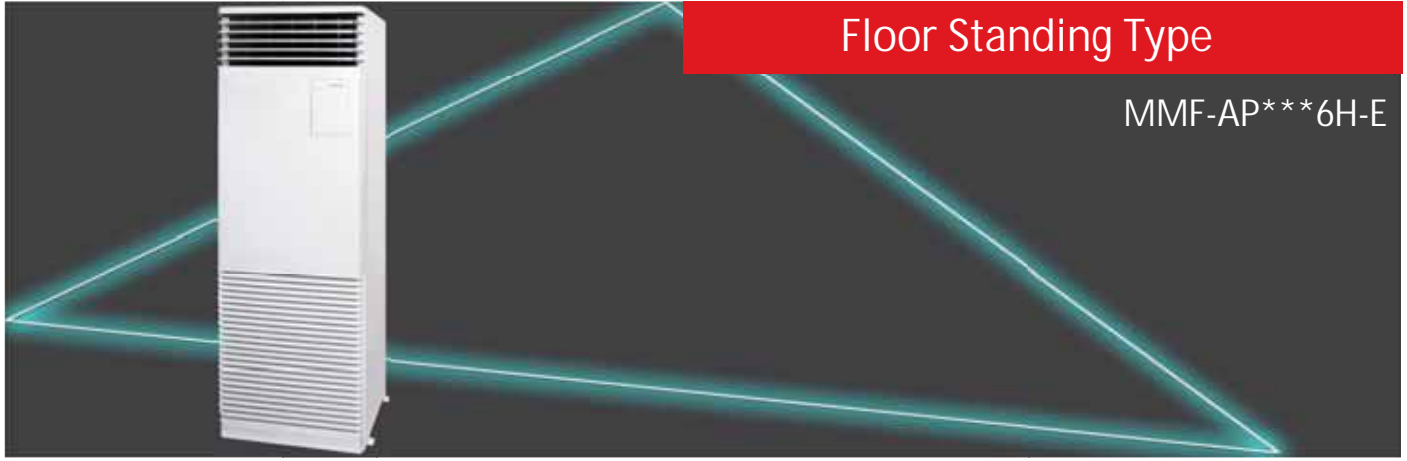

## Floor Standing Type

MMF-AP\*\*\*6H-E

**Thin profile suits interior design**  
Slender, space-saving type (1.7–8.0HP)

**Wide outlet**

Corner location is also possible, with right and left auto swing.  
Set the vertical angle manually.

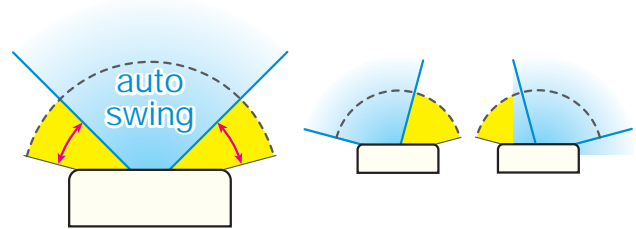

### MMF-AP0156H-E to AP0566H-E

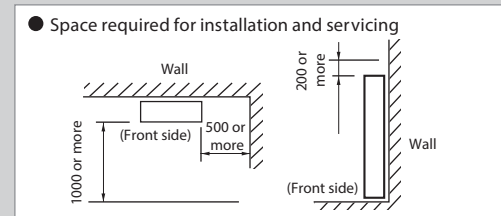
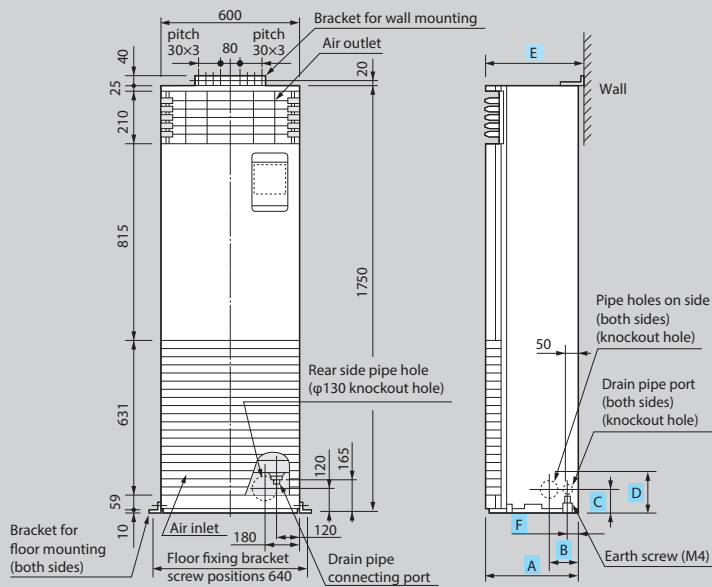

Model	MMF-	A	B	C	D	E	F
AP0154H-E to AP0274H-E		200	107	132	157	210	50
AP0364H-E to AP0564H-E		380	125	120	160	390	40

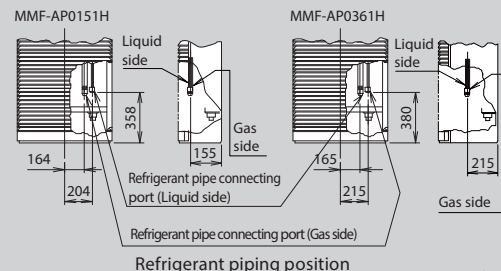

(Unit: mm)

## Technical specifications

Model name	MMF-	AP0156H-E	AP0186H-E	AP0246H-E	AP0276H-E	AP0366H-E	AP0486H-E	AP0566H-E
Cooling/Capacity*1	(kW)	4.5	5.6	7.1	8.0	11.2	14.0	16.0
Electrical characteristics	Power requirements	1-phase 50Hz 230V (220–240V) / (Separate power supply for indoor units required.)						
	Power consumption 50 Hz	(kW)	0.055		0.089		0.135	0.160
External dimensions	Height	(mm)	1750					
	Width	(mm)	600					
	Depth	(mm)	210			390		
Total weight	(kg)	46		47		62		
Fan unit	Standard air flow (High/Mid/Low)	(m <sup>3</sup> /h)	900/780/660		1200/990/840	1920/1620/1380	2160/1730/1560	
	Motor output	(W)	62		62	109	109	
Connecting pipe	Gas side	(mm)	φ12.7		φ12.7			
	Liquid side	(mm)	φ6.4		φ9.5			
	Drain port	(nominal dia.)	20 (one side of male screw)					
Sound pressure level*2 (High/Mid/Low)	(dB(A))	46/42/37		49/45/39		51/46/41	54/49/44	

Note 1 : The capacities are measured under the conditions specified by JIS B 8615 based on the reference piping.  
The reference piping consists of 5 m of main piping and 2.5 m of branch piping connected with 0 m height.

Note 2 : The sound level are measured in an anechoic chamber in accordance with JIS B 8616.

Normally, the values measured in the actual operating environment become larger than the indicated values due to the effects of external sound.

Note : Rated conditions Cooling : Indoor air temperature 27°C DB/19°C WB, Outdoor air temperature 35°C DB

Heating : Indoor air temperature 20°C DB, Outdoor air temperature 7°C DB/6°C WB

## Large capacity floor standing type



MMF-AP0724DH-V

MMF-AP1444DH-V

### Floor Standing <Duct Type>

(50 Hz/60 Hz)

MMF-AP0724DH-V/MMF-AP0964DH-V

MMF-AP1444DH-V/MMF-AP1924DH-V

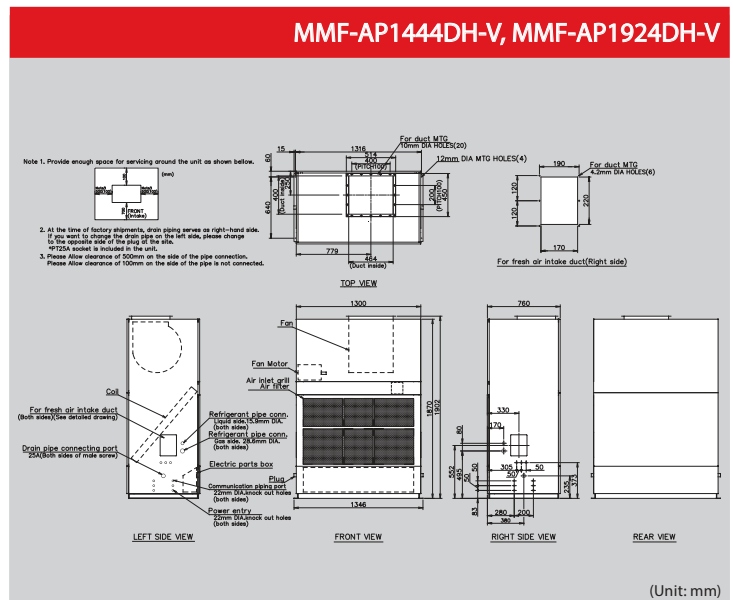
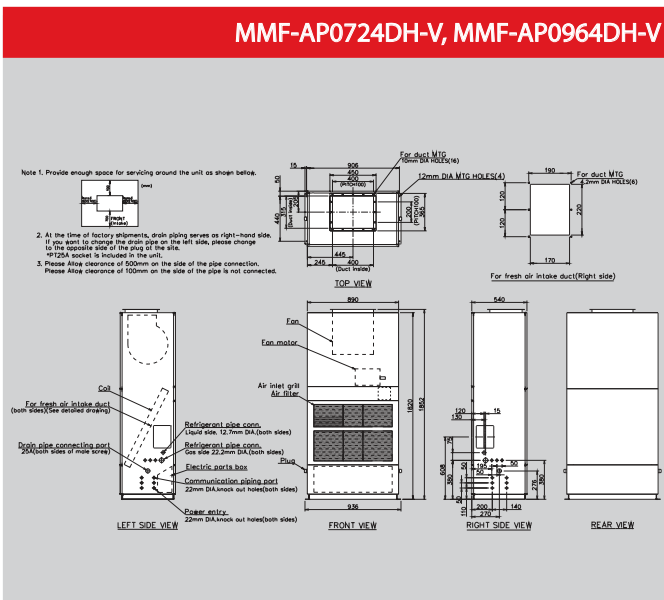

### Technical specifications

Model name	MMF-	AP0724DH-V	AP0964DH-V	AP1444DH-V	AP1924DH-V	
Cooling/Heating capacity*1	(kW)	22.4/25.0	28.0/31.5	45.0/50.0	56.0/63.0	
Electrical characteristics	Power requirements	3 phase 50/60Hz 400V(Separate power supply for indoor units is required.)				
	Power consumption 50 Hz/60 Hz	(kW)	0.59/0.70	0.80/0.99	1.04/1.28	1.79/2.26
External dimensions	Height	(mm)	1820		1870	
	Width	(mm)	890		1300	
	Depth	(mm)	540		760	
Total weight	(kg)	170	170	280	290	
Fan unit*2	Standard air flow	(m <sup>3</sup> /h)	3600	4200	7200	8400
	Motor output	(kW)	1.5	1.5	2.2	3.7
	External static pressure (50Hz/60Hz)	(Pa)	43/122	39/148	28/111	86/222
Connecting pipe	Gas side	(mm)	ø22.2		ø28.6	
	Liquid side	(mm)	ø12.7		ø15.9	
	Drain port	(nominal dia.)	25 (Both sides of male screw)			
Sound pressure level*3	(dB(A))	54/56	55/57	61/63	62/64	

Note 1 : The capacities and electrical characteristics are measured under the conditions specified by JIS B 8615.

Note 2 : As air volume is fixed, by remote controller, air volume cannot be changed.

When required high static pressure and air volume change, a pulley change is requested.

Note 3 : The sound level are measured in an anechoic chamber in accordance with JIS B 8616.

Normally, the sound level measured in the actual operating environment become bigger than the rated figures due to the effects of external sound.

Note : Rated conditions Cooling : Indoor air temperature 27°C DB/19°C WB, Outdoor air temperature 35°C DB

Heating : Indoor air temperature 20°C DB, Outdoor air temperature 7°C DB/6°C WB



Large capacity floor standing type

Floor Standing <Direct Type>

(50 Hz)

MMF-AP0724H-VA/MMF-AP0964H-VA  
MMF-AP1444H-VA/MMF-AP1924H-VA

(60 Hz)

MMF-AP0724H-VB/MMF-AP0964H-VB  
MMF-AP1444H-VB/MMF-AP1924H-VB

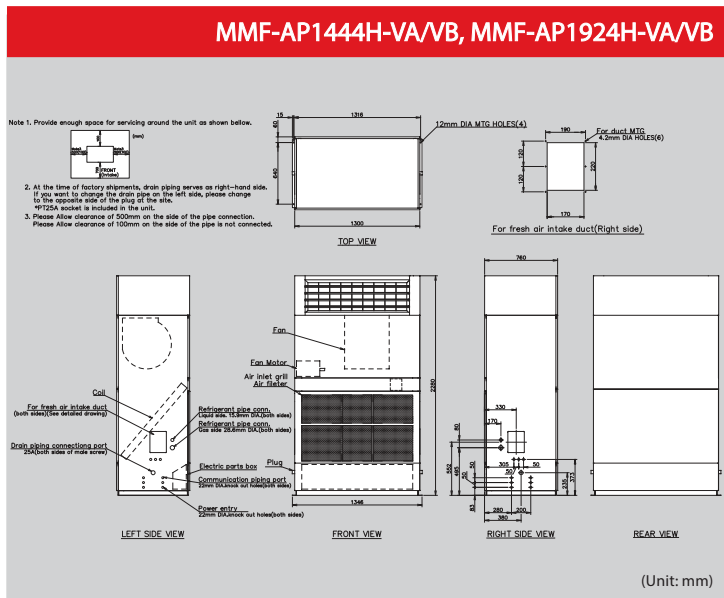
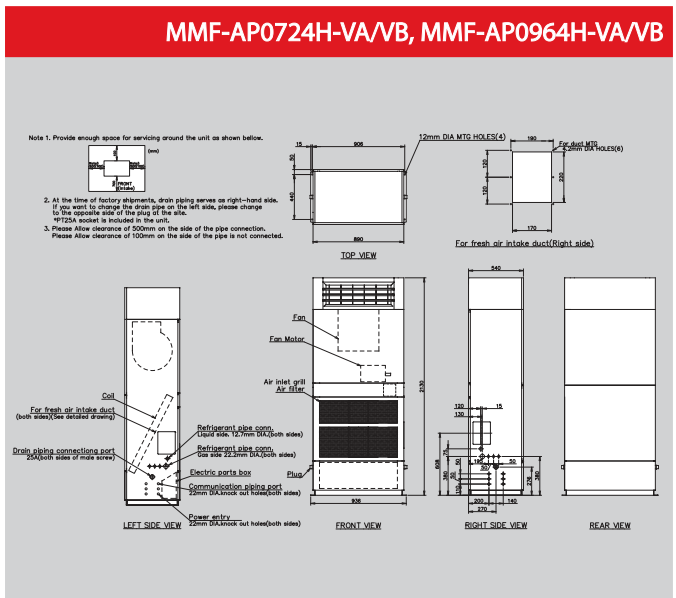

Technical specifications

Model name (50Hz/60Hz)	MMF-	AP0724H-VA/VB	AP0964H-VA/VB	AP1444H-VA/VB	AP1924H-VA/VB	
Cooling/Heating capacity*1	(kW)	22.4/25.0	28.0/31.5	45.0/50.0	56.0/63.0	
Electrical characteristics	Power requirements	3 phase 50/60Hz 400V(Separate power supply for indoor units is required.)				
	Power consumption 50 Hz/60 Hz	(kW)	0.56/0.53	0.84/0.79	1.24/1.19	2.07/2.05
External dimensions	Height	(mm)	2,130		2,280	
	Width	(mm)	890		1,300	
	Depth	(mm)	540		760	
Total weight	(kg)	182	188	320	320	
Fan unit*2	Standard air flow	(m <sup>3</sup> /h)	3,600	4,200	7,200	8,400
	Motor output	(kW)	0.75	1.5	2.2	2.2
Connecting pipe	Gas side	(mm)	ø22.2		ø28.6	
	Liquid side	(mm)	ø12.7		ø15.9	
	Drain port	(nominal dia.)	25 (Both sides of male screw)			
Sound pressure level*3	(dB(A))	62	63	64	66	

Note 1 : The capacities and electrical characteristics are measured under the conditions specified by JIS B 8615.

Note 2 : As air volume is fixed, by remote controller, air volume cannot be changed.

When required high static pressure and air volume change, a pulley change is requested.

Note 3 : The sound level are measured in an anechoic chamber in accordance with JIS B 8616.

Normally, the sound level measured in the actual operating environment become bigger than the rated figures due to the effects of external sound.

Note : Rated conditions Cooling : Indoor air temperature 27°C DB/19°C WB, Outdoor air temperature 35°C DB

Heating : Indoor air temperature 20°C DB, Outdoor air temperature 7°C DB/6°C WB

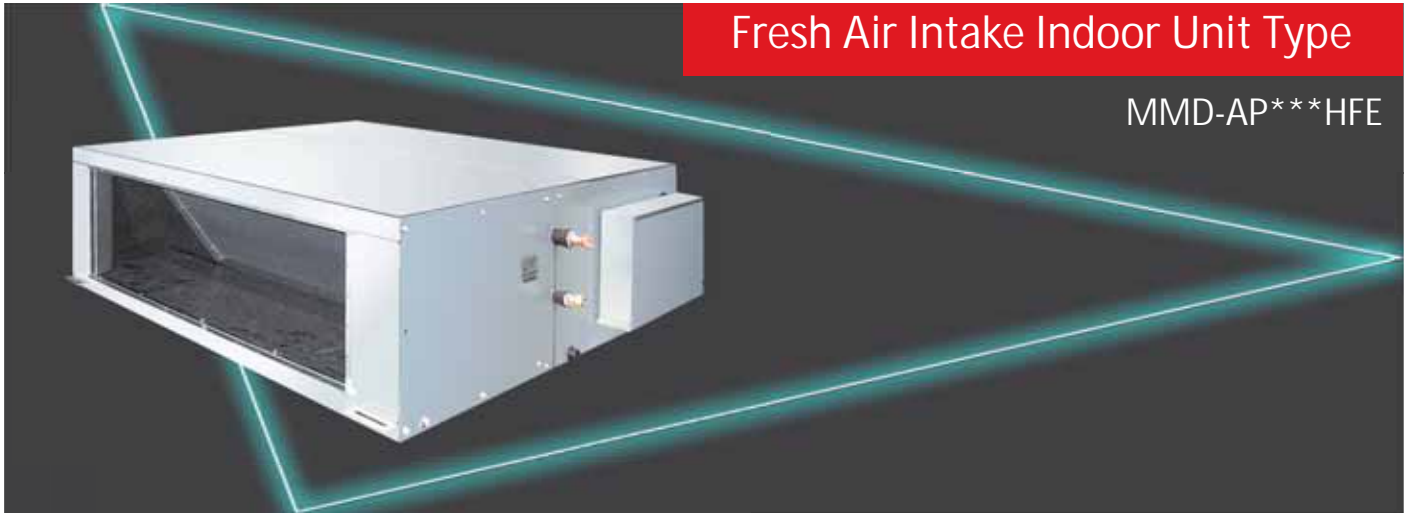

## Fresh Air Intake Indoor Unit Type

MMD-AP\*\*\*HFE

### Air controller for fresh-air intake

Outside static pressure maximum 230 Pa (in case of 50 Hz of 5HP).  
Use of high-performance filter provides more comfortable room environment.  
Introduces outdoor air at a temperature close to that of the indoor air.  
Primary processing of fresh outdoor air.

Fresh-air intake often influences the system, rendering normal control of the air conditioner difficult, or placing large loads on the system and its cooling performance.  
Therefore it is frequently adopted to handle the fresh air to a certain condition before the fresh air will enter in the main air conditioner.

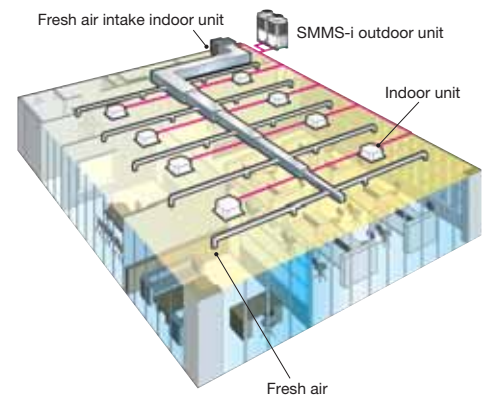

This device is known as a fresh air intake indoor unit.

NOTE: The fresh air intake indoor unit is an air conditioner provided to handle the fresh air load and is not to control the room temperature. For correspondence to the load of the indoor air controller, set an air conditioner separately.

### Technical specifications

Model name		MMD-	AP0481HFE	AP0721HFE	AP0961HFE
Cooling/ capacity (Note 1)		(kW)	14.0	22.4	28.0
Electrical characteristics	Power supply	(kW)	1-phase 50 Hz 230 V (220-240 V)		
	Power consumption	(kW)	0.28	0.45	0.52
External dimensions	Main unit	Height	(mm)	492	
		Width	(mm)	892	1392
		Depth	(mm)	1262	
Total weight		(kg)	93	144	
Fan unit	Standard air flow	(m <sup>3</sup> /h)	1080	1680	2100
	Motor output	(kW)	0.160	0.160×2	
	External static pressure 50 Hz/60 Hz	(Pa)	170-210-230 / 115-215-260	140-165-180 / 150-210-235	160-190-205 / 80-180-220
	Air flow limit Lower limit/Upper limit	(m <sup>3</sup> /h)	756/1188	1176/1848	1470/2310
Connecting pipe	Gas side	(mm)	ø15.9	ø22.2	
	Liquid side	(mm)	ø9.5	ø12.7	
	Drain port	(mm)	25		
Sound pressure level (Note 2) (High/Med./Low)		(dB(A))	45/43/41	46/45/44	
Operation range	Cooling (Note 3)	(°C)	5 - 43		
	Heating (Note 4)	(°C)	-5 - 43		

\* The setting temperature is 16 - 27°C (standard FCU...18 - 29°C).

\* An optional humidifier is not available with fresh air intake indoor unit.

\* Height difference between fresh air intake indoor units must be within 0.5 m. Height difference between fresh air intake indoor unit and standard FCU must be within 30 m.

**NOTE 1** Rated conditions Cooling: Outdoor air temperature 33°C DB/28°C WB setting temperature 18°C  
Heating: Outdoor air temperature 0°C DB/-2.9°C WB setting temperature 25°C  
Piping: Length 7.5 m / Height 0 m

**NOTE 2** Normally, the values measured in the actual operating environment become large than the indicated values due to the effects of external sound.

**NOTE 3** \* When supply air temperature is "setting temperature + 3°C" or less, fresh air intake indoor unit operates as FAN mode.

\* When supply air temperature is 19°C or less, Fresh Air Intake Indoor unit operates as FAN mode.

**NOTE 4** \* When supply air temperature is "setting temperature -3°C" or over, fresh air intake indoor unit operates as FAN mode.

### Use Conditions

- In COOL mode, if temperature of the fresh air is below the setup temp. of +3°C, FAN status is automatically made. When temperature of the fresh air is below 19°C, FAN status is also made regardless of the setup temperature.



### Operable mode and discharge temperature setup range

Operation mode	At shipment from factory	Setup range
COOL	18°C	16 to 27°C

### MMD-AP0481HFE to AP0961HFE

Long hole for M10 hanging bolt

Type	Hole dia. -Width x Length
0481	4-φ12 x 40
0721, 0961	4-φ12 x 92

● Space required for installation and servicing

Blow-off port  
Discharge temp sensor  
Discharge port connecting flange (K)  
(Accessory for main unit of product)

Refrigerant pipe connecting port (Gas pipe M)  
Refrigerant pipe connecting port (Liquid pipe N)  
Electric parts box (With cover)  
Drain pipe connecting port

Suction port  
Suction port connecting flange (L)  
(Accessory for main unit of product)

Model MMD-	A	B	C	D	E	F	G	H	I	J	K	L	M	N
AP0961HFE	1392	1260	250	250	250	250	250	250	250	250	10-M6	10-M6	φ22.2 brazing	φ12.7 flare
AP0721HFE	1392	1260	250	250	250	250	250	250	250	250	10-M6	10-M6	φ22.2 brazing	φ12.7 flare
AP0481HFE	892	810	215	107.5	107.5	215	—	250	250	—	8-M6	6-M6	φ15.9 flare	φ9.5 flare

(Unit: mm)

### Options

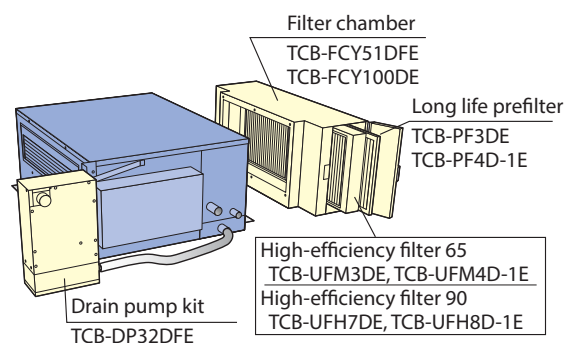



## Air -to- Air Heat Exchanger with DX-coil

MMD-VN\*\*\*HEXE/HEXE2

### Greater comfort and reduced load

Functionality built into the cooling system reduces load on cooling beyond that of the heat exchanger itself. This improves air quality and ensures maximum comfort throughout room being cooled.

### Flexible control

Supply and exhaust fan speed ratios can be changed for improved air volume control that best matches the needs of the environment and location.

### Free cooling at night

When the air outdoors is cooler at night, the system expels warm air from the room. This reduces the air conditioning load the next day for improved energy efficiency.



Remote controller  
NRC-01HE

### Technical specifications

Model name		MMD-	VN502HEXE	VN802HEXE	VN1002HEXE	
Fresh air conditioning load	Cooling (*1)	(kW)	4.10 (1.30)	6.56 (2.06)	8.25 (2.32)	
Power supply			1-phase 50Hz 230V (220–240V) / 1-phase 60Hz 220V (Separate power supply for indoor units is required.)		1-phase 50Hz 230V (220V-240V) (Separate power supply for indoor units is required.)	
Temperature exchange efficiency 50Hz / 60Hz	High	(%)	70.5	70.0	65.5	
	Mid	(%)	70.5	70.0	65.5	
	Low	(%)	71.5	72.5	67.5	
Enthalpy exchange efficiency 50Hz / 60Hz	Cooling	High	(%)	56.5	56.0	52.0
		Mid	(%)	56.5	56.0	52.0
		Low	(%)	57.5	59.0	54.5
	Heating	High	(%)	68.5	70.0	66.0
		Mid	(%)	68.5	70.0	66.0
		Low	(%)	69.0	73.0	68.5
Fan unit 50Hz / 60Hz	Standard air flow	High	(m <sup>3</sup> /h)	500	800	950
		Mid	(m <sup>3</sup> /h)	500	800	950
		Low	(m <sup>3</sup> /h)	440	640	820
	External static pressure	High	(Pa)	120	120	135
		Mid	(Pa)	105	100	120
		Low	(Pa)	115	105	105
Sound pressure 50Hz / 60Hz	High	(dB)	37.5	41.0	43.0	
	Mid	(dB)	36.5	40.0	42.0	
	Low	(dB)	34.5	38.0	40.0	
External Dimensions	Height	(mm)	430			
	Width	(mm)	1140	1189		
	Depth	(mm)	1690	1739		
Total weight		(kg)	84	100	101	
Connecting piping	Gas side	(mm)	ø9.5	ø12.7		
	Liquid side	(mm)	ø6.4			
Drain port		(Nominal dia .mm)	25(Polyvinyl chloride tube)			

(\*1) Cooling and heating capacities are based on the following conditions:  
Cooling capacities are based on : indoor temperature :27 °CDB/19°CWB, Outdoor temperature : 35°CDB  
Heating capacities are based on : indoor temperature :20 °CDB, Outdoor temperature : 7 °CDB/6°CWB  
Fan is based on High and Middle  
( ): The figures in ( ) indicate the heat reclaimed from the heat recovery ventilator.

MMD-VN502HEXE

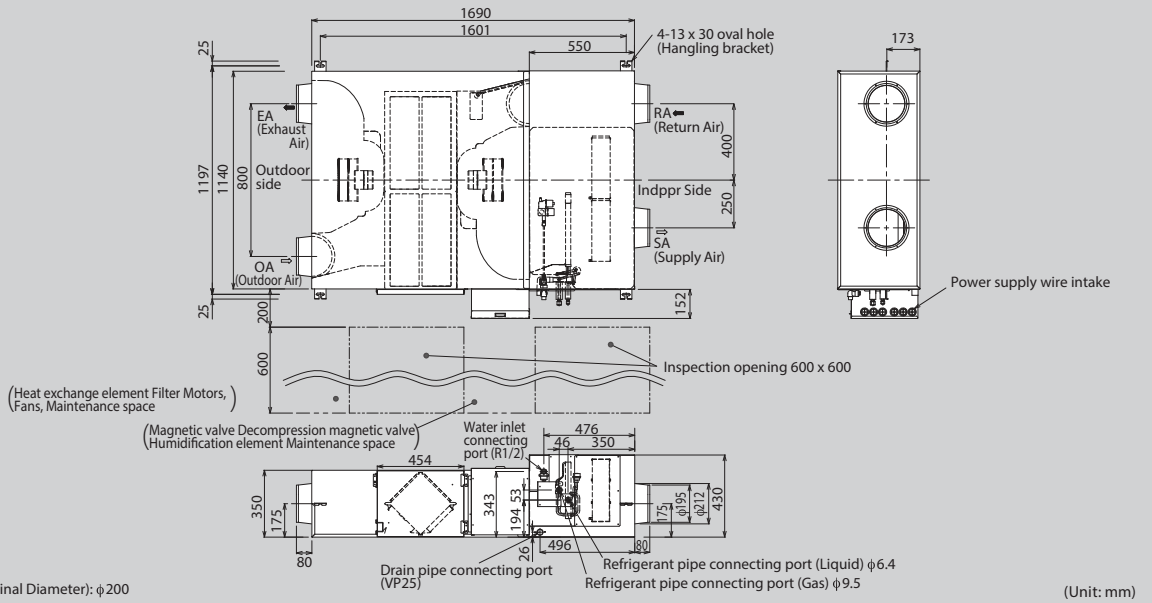

MMD-VN802HEXE to VN1002HEXE/2

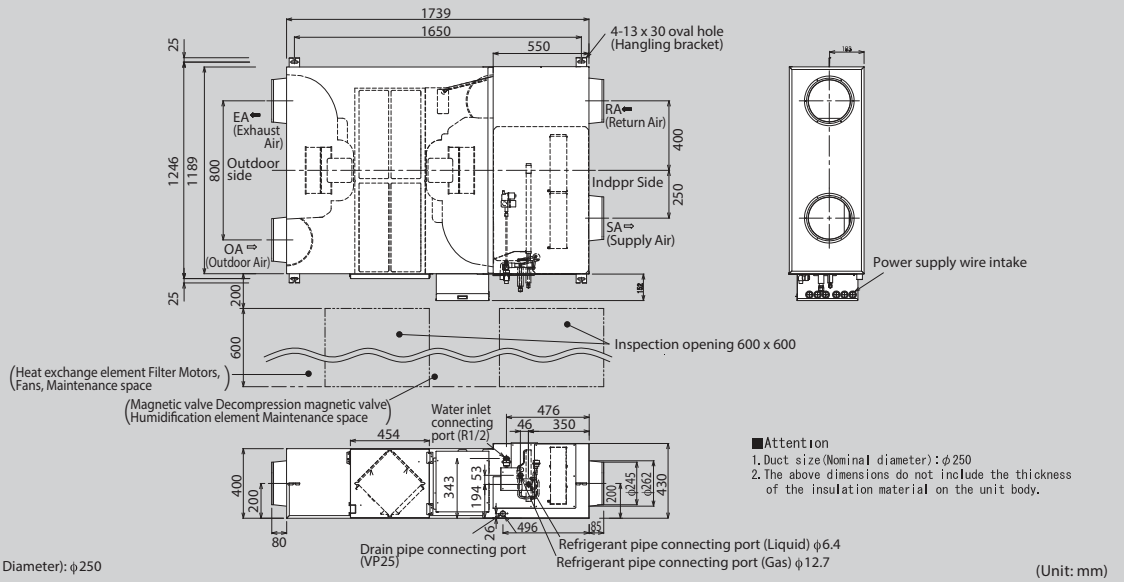

Options

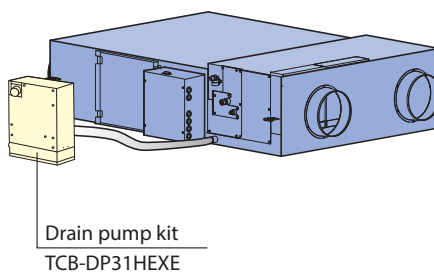



## Air-to-Air Heat Exchanger (Stand alone unit)

VN-M\*\*\*HE

### Greater comfort and reduced load

Easily integrated into air conditioning systems of 150m<sup>3</sup>/h to 2000m<sup>3</sup>/h air volume, the air-to-air heat exchangers use exhaust air to pre-condition the incoming air, thus reducing the cooling or heating load and the overall size of the required system.

### Flexible control

Supply and exhaust fan speed ratios can be changed for improved air volume control that best matches the needs of the environment and location.

### Free cooling at night

When the air outdoors is cooler at night, the system expels warm air from the room. This reduces the air conditioning load the next day for improved energy efficiency.

### Easy maintenance

The heat exchange element can be washed in water.



Remote controller  
NRC-01HE

\* Does not connect to refrigerant piping from outdoor unit. Control wires can be connected.

### Technical specifications

Model name	VN-	M150HE	M250HE	M350HE	M500HE	M650HE	M800HE	M1000HE	M1500HE	M2000HE	
Power supply (V)	1-phase 50Hz 230V (220-240V) / 1-phase 60Hz 220V (Separate power supply for indoor units required.)										
Power consumption 50Hz/60Hz (W)	Fan speed										
	(Extra high)	68-78	123-138	165-182	214-238	262-290	360-383	532-569	751-786	1084-1154	
	High	59-67	99-111	135-145	176-192	240-258	339-353	494-538	708-784	1032-1080	
Air volume (m <sup>3</sup> /h)	Low	42-47	52-59	82-88	128-142	178-191	286-300	353-370	570-607	702-742	
	(Extra high)	150	250	350	500	650	800	1000	1500	2000	
	High	150	250	350	500	650	800	1000	1500	2000	
External static pressure (Pa)	Low	110	155	210	390	520	700	755	1200	1400	
	(Extra high)	82-102	80-98	114-125	134-150	91-107	142-158	130-150	135-156	124-143	
	High	52-78	34-65	56-83	69-99	58-82	102-132	97-122	103-129	92-116	
Sound pressure level (dB(A))	Low	47-64	28-40	65-94	62-92	61-96	76-112	84-127	112-142	110-143	
	(Extra high)	26-28	29.5-30	34-35	32.5-34	34-36	37-38.5	39.5-40.5	38-39	41-42.5	
	High	24-25.5	25-27	30-32	29.5-31	33-34	35.5-37	38.5-40	36.5-37.5	39.5-41	
Temperature exchange efficiency (%)	Low	20-22	21-22	27-29	25-29	31-32.5	33.5-35	34-35.5	35-37.5	37-39	
	(Extra high)	81.5	78	74.5	76.5	75	76.5	73.5	76.5	73.5	
	High	81.5	78	74.5	76.5	75	76.5	73.5	76.5	73.5	
Enthalpy exchange efficiency (%)	for heating	Low	83	81.5	79.5	78	76.5	77.5	77	79	77.5
		(Extra high)	74.5	70	65	72	69.5	71	68.5	71	68.5
		High	74.5	70	65	72	69.5	71	68.5	71	68.5
	for cooling	Low	76	74	71.5	73.5		71.5		73.5	72
		(Extra high)	69.5	65	60.5	64.5	61.5	64	60.5	64	60.5
		High	69.5	65	60.5	64.5	61.5	64	60.5	64	60.5
Low	71	69	67	66.5	64	65.5	64.5	67	65.5		
Dimensions (Length x Width x Height) (mm)	900 x 900 x 290			1140 x 1140 x 350			1189 x 1189 x 400		1189 x 1189 x 810		
Weight (kg)	36			38		53		70		143	
Duct diameter (mm)	100		150		200		250		inside: 250, outside: 283 x 730		
Operating range	Around unit	-10°C - 40°C 80% RH or less									
	Outdoor Air (OA)	-15°C (*1) - 43°C RH									
	Return Air (RA)	5°C - 40°C 0% RH or less									

\* Air volume can be changed over to high (extra high) mode or low mode.

\* Sound pressure level is measured 1.5m below the center of the unit.

\* Sound pressure level is the value which was measured at the acoustic room.

\* The actual values in an external operating environment are generally higher than the indicated values due to the contribution from ambient noise.

\* Sound pressure level is less than 70 dBA

VN-M150HE to VN-M350HE

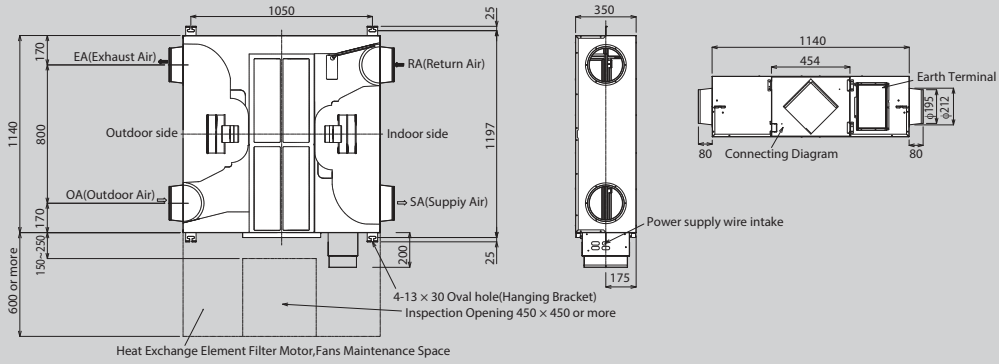

Duct size (Nominal Diameter):  $\phi 200$

(Unit: mm)

VN-M500HE, VN-M650HE

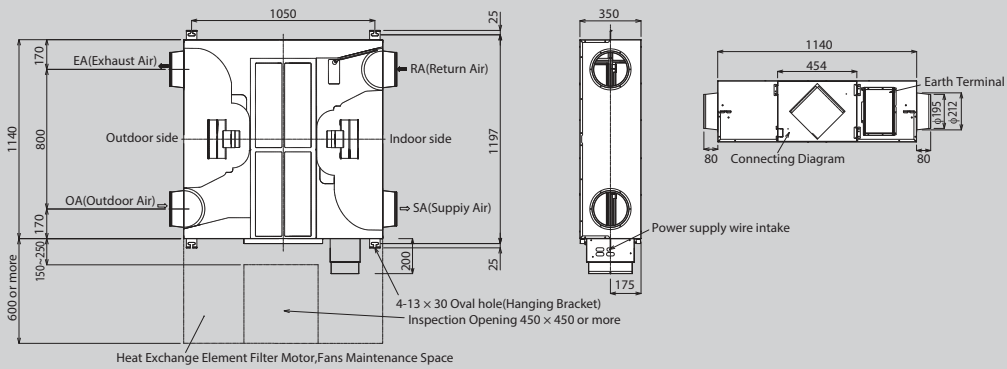

Duct size (Nominal Diameter):  $\phi 200$

(Unit: mm)

VN-M800HE, VN-M1000HE

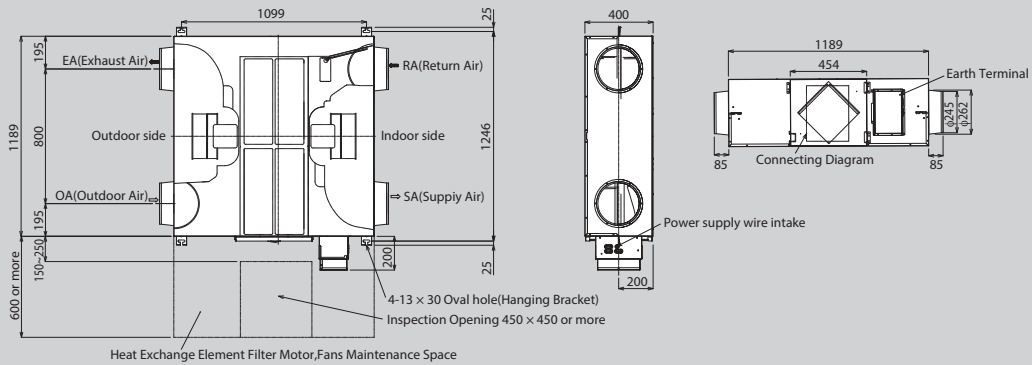

Duct size (Nominal Diameter):  $\phi 250$

(Unit: mm)

VN-M1500HE, VN-M2000HE

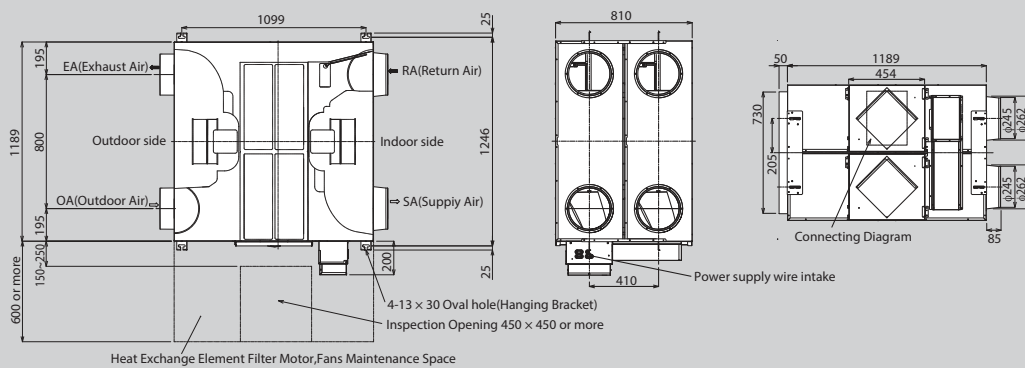

Duct size (Nominal Diameter):  $\phi 250$

(Unit: mm)

## Indoor unit accessories

Indoor unit	Parts Name	Model Name	Applied Model	Notes	Remarks
4-way air discharge cassette type	Ceiling panel	RBC-U31PG(W)-E	MMU-AP***4HP-E	Required accessory	
	Fresh air inlet box	TCB-GB1602UE		For fresh air intake by using the knockout hole of fresh air filter chamber. (dia.=100 mm)	Use with TCB-GFC1602UE
	Fresh air filter chamber	TCB-GFC1602UE		For fresh air inlet box	
	Auxiliary fresh air flange	TCB-FF101URE2		For easy fresh air intake by using the knockout hole of indoor unit. (dia.=100 mm)	
	Spacer for height	TCB-SP1602UE		Height=50 mm	
	Air discharge direction kit	TCB-BC1602UE		Air direction change by cutting off air discharge port (3 pcs.)	
Compact 4-way cassette (600 × 600) type	Ceiling panel	RBC-UM11PG(W)E	MMU-AP***4MH-E	Required accessory	
	Auxiliary fresh air flange	TCB-FF101URE2		For easy fresh air intake by using the knockout hole of indoor unit. (dia.=100 mm)	
2-way air discharge cassette type	Ceiling panel	RBC-UW283PG(W)-E	MMU-AP0072 to 0152WH	Required accessory	
		RBC-UW803PG(W)-E	MMU-AP0182 to 0302WH		
		RBC-UW1403PG(W)-E	MMU-AP0362/0482/0562WH		
	Super long life filter	TCB-LF283UW-E	MMU-AP0072 to 0152WH	Dust collecting effect: 50% (Weight method)	Use with TCB-FC283UW-E
		TCB-LF803UW-E	MMU-AP0182 to 0302WH		Use with TCB-FC803UW-E
	Filter chamber	TCB-LF1403UW-E	MMU-AP0362/0482/0562WH	For super long life filter	
		TCB-FC283UW-E	MMU-AP0072 to 0152WH		
TCB-FC803UW-E		MMU-AP0182 to 0302WH			
Auxiliary fresh air flange	TCB-FC1403UW-E	MMU-AP0362/0482/0562WH			
1-way air discharge cassette type	Ceiling panel	RBC-UY136PG	MMU-AP***2WH	Required accessory	
		RBC-US21PGE	MMU-AP***4YH-E	Required accessory	
	Front air discharge unit	TCB-BUS21HWE	MMU-AP***4SH-E		
	Auxiliary fresh air flange	TCB-FF101URE2		For easy fresh air intake by using the knockout hole of indoor unit. (dia.=100 mm)	
Concealed duct type	Spigot shaped flange	TCB-SF56C6BPE	MMD-AP0076 to 0186BHP-E		
		TCB-SF80C6BPE	MMD-AP0246/0276/0306BHP-E		
		TCB-SF160C6BPE	MMD-AP0366/0486/0566BHP-E		
Concealed duct high static pressure type	Long Life Filter Kit	TCB-LK801D-E	MMD-AP0186/0246/0276HP-E		
		TCB-LK1401D-E	MMD-AP0366/0486/0586HP-E		
	Spigot Shaped Flange	TCB-SF80C6BPE	MMD-AP0186/0246/0276HP-E		
		TCB-SF160C6BPE	MMD-AP0366/0486/0586HP-E		
	Auxiliary fresh air flange	TCB-SF160C6BPE	MMD-AP***6HP-E		
	High-efficiency filter 65	TCB-UFM3DE	MMD-AP0724/0964H-E	Dust collecting effect: 65%(NBS Colorimetric method)	
	High-efficiency filter 90	TCB-UFH7DE	MMD-AP0724/0964H-E	Dust collecting effect: 90%(NBS Colorimetric method)	
	Long life prefilter	TCB-PF3DE	MMD-AP0724/0964H-E	Dust collecting effect: 50%(Weight method)	
	Filter chamber	TCB-FCY100DE	MMD-AP0724/0964H-E	For high-efficiency filter or long life prefilter	
Drain pump kit	TCB-DP32DE	MMD-AP0724/0964H-E	Stand-up 330 mm or less (from bottom face of ceiling)		
Slim duct type	Auxiliary fresh air flange	TCB-FF101URE2	MMD-AP***4SPH-E	For fresh air intake by using the knockout hole of indoor unit. (dia.=100 mm)	
Ceiling type	Drain pump kit	TCB-DP31CE	MMC-AP0157/0187HP-E	Stand-up 600 or less (from bottom face of ceiling)	Use with TCB-KP13CE
		TCB-KP13CE	MMC-AP0247 to 0567HP-E		Use with TCB-KP23CE
	Elbow piping kit	TCB-KP23CE	MMC-AP0157/0187HP-E	Needed when drain pump kit is used	
Air to Air Heat Exchanger with DX-coil	Drain pump kit	TCB-DP31HEXE	MMD-VN502 to 1002HEXE	Stand-up 330 mm or less (from bottom face of ceiling)	
Fresh air intake indoor unit type	High-efficiency filter 65	TCB-UFM3DE	MMD-AP0721/0961HFE	Dust collecting effect: 65% (NBS Colorimetric method)	Use with TCB-PF3DE
		TCB-UFM4D-1E	MMD-AP0481HFE		Use with TCB-PF4D-1E
	High-efficiency filter 90	TCB-UFH7DE	MMD-AP0721/0961HFE	Dust collecting effect: 90% (NBS Colorimetric method)	Use with TCB-PF3DE
		TCB-UFH8D-1E	MMD-AP0481HFE		Use with TCB-PF4D-1E
	Long life prefilter	TCB-PF3DE	MMD-AP0721/0961HFE	Dust collecting effect: 50% (Weight method)	
		TCB-PF4D-1E	MMD-AP0481HFE		
	Filter chamber	TCB-FCY51DFE	MMD-AP0481HFE	For high-efficiency filter or long life prefilter	
		TCB-FCY100DE	MMD-AP0721/0961HFE		
Drain pump kit	Drain pump kit	MMD-	Stand-up 330 or less (from bottom face of ceiling)		

**Combination Pattern**

1) Accessory for 4-way air discharge cassette type: combination pattern

		1	2	3	4	5	6
		Ceiling panel	Fresh air inletbox + Fresh air filter chamber	Fresh air filter chamber	Auxiliary fresh air flange	Spacer for height adjustment	Air discharge direction kit
1	Ceiling panel		OK	OK	OK	OK	OK
2	Fresh air inlet box + Fresh air filter chamber	OK			OK	—	OK
3	Fresh air filter chamber	OK			OK	OK	OK
4	Auxiliary fresh air flange	OK	OK	OK		OK	OK
5	Spacer for height adjustment	OK	—	OK	OK		OK
6	Air discharge direction kit	OK	OK	OK	OK	OK	



# Remote controllers

## Air-conditioning Management System on site

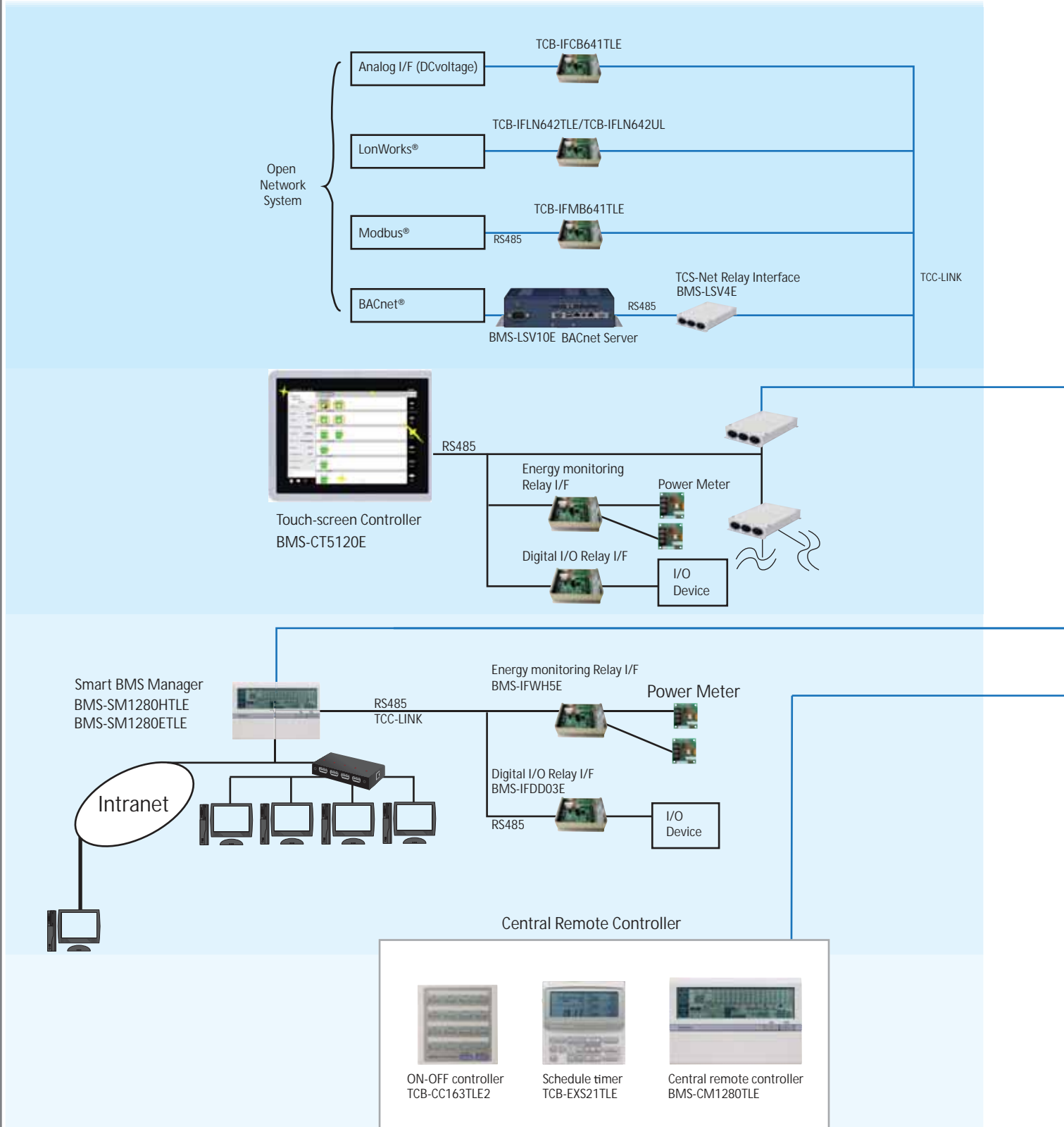

1.LonWorks® : Registered trademark by Echelon corporation.  
 2.BACnet® : ANSI/ASHRAE 135-1995, A data Communication Protocol for Building Automation and Control Network.  
 3.Modbus® : Registered trademark by Schneider E.

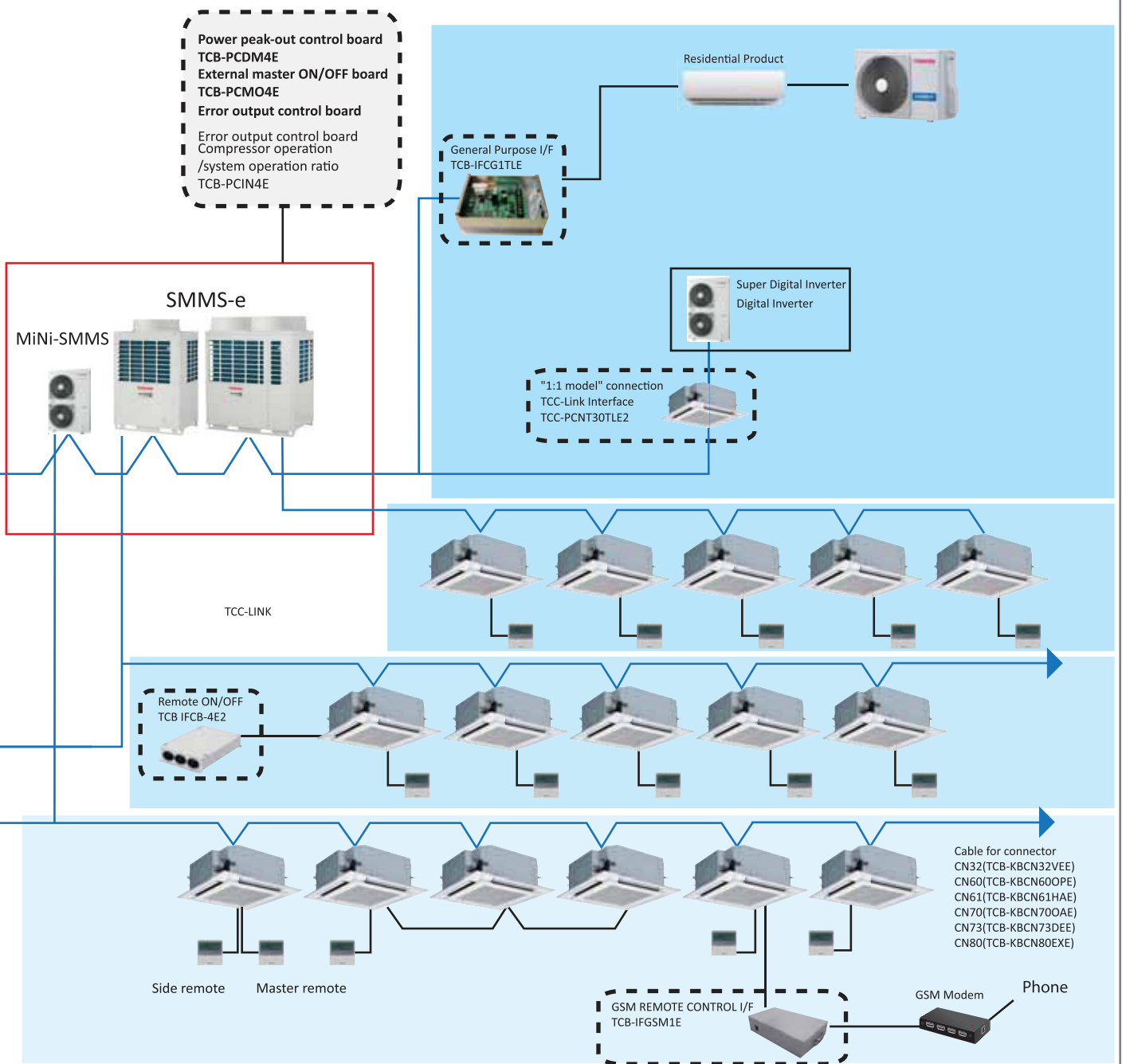

**Wire remote controller/Wireless remote controller**

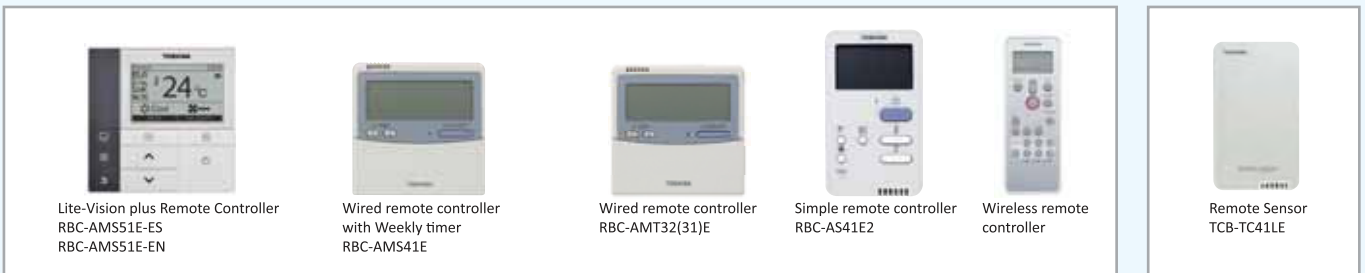

## Wired remote controller



### Lite-Vision plus Remote Controller RBC-AMSS1E-ES RBC-AMSS1E-EN

Wired remote controller with a built in 7-day timer-featuring a new multi-language, LCD display with backlight, energy saving options and a return back function.

- Possibility to set and display the room name to easily set-up and monitor the working parameter.
- New modern and desirable controller design with menu driven display.
- Save mode by schedule timer to optimise energy consumption.
- Room temperature display always available.
- Two "Hot Keys" (F1, F2) for easy operation of air conditioner functions.
- Easy to read layout including display of indoor unit model name and serial number.
- Built-in backup power. Settings are kept in memory up to 72 hours in case of power failure.
- Remote TA sensor available in controller.
- Can be connected to a single indoor unit or a group of up to 8 indoor units.



### Standard Remote controller RBC-AMT32E

Standard wired remote controller can be connected to a single indoor unit or a group of up to 8 indoor units.

Power save operation limits the greatest current value. The remote controller allows error to be displayed while the protective device works or a error occurs.



### Remote controller with weekly timer (7-day timer function) RBC-AMS41E

- Clock display
- Schedule timer: Possible to program schedule timer (7-day timer) function
- Possible to program 8 functions for each day of the week

\*The following items can be set in program: operation time, operation start/stop, operation mode, temperature setting, restriction on button operation



### Simple wired remote controller RBC-AS41E

- Start/Stop
- Temperature setting
- Air flow changing
- Check code display

## Wireless remote controller



### Wireless remote controller kit & sensor unit (receiver unit)

- Start/Stop •Changing mode •Temperature setting
- Air flow changing
- Timer function  
Either "ON" time or "OFF" time or "CYCLIC" can be set how many 30 min. later ON or OFF is operated.
- Control by 2 remote controllers is available. Two wireless remote controllers can operate one indoor unit. The indoor unit can then be operated separately from the two different locations.
- Check code display

\*The wireless remote control cannot be connected to concealed duct high static pressure type.



### RBC-AX33CE Integral receiver (For ceiling) (MMC-AP\*\*\*7HP-E) (MMU-AP\*\*\*4SH-E)



### RBC-AX32U(W)-E Integral receiver (For 4-way air discharge cassette) (MMU-AP\*\*\*4HP-E)



### TCB-AX32E2 Stand alone receiver (For 4-way air discharge cassette, compact 4-way cassette (600 x 600), 2-way air discharge cassette, ceiling, concealed duct standard, slim duct, floor standing cabinet, floor standing, 1-way discharge cassette (MMU-AP \*\*\*4YH-E/SH-E)



### RBC-AX23UW(W)-E Integral receiver (For 2-way air discharge cassette) (MMU-AP \*\*\*2WH)

**Central remote controller**



**Central remote controller**  
BMS-CM1280TLE

- **Operation**  
Individual operation of 128 indoor units available  
Return Back Operation  
Weekly Schedule Operation\*  
(ON/OFF)  
\* Schedule timer necessary
- **Monitoring**  
Zone setting (64 zones x 2)  
Individual unit operation mode operation restriction  
Alarm display  
Control input  
Status output



**ON-OFF controller**  
TCB-CC163TLE2

- Individual control of up to 16 indoor units.
- Setting of simultaneous ON/OFF 3times per day combined with the weekly timer.



**Schedule timer**  
TCB-EXS21TLE

- **Schedule timer mode**
  - 6 programmings per day
  - Enabling 8 groups to be programmed
  - A maximum of 64 indoor units can be controlled
  - A maximum of 100 hours back-up power supply
- **Weekly timer mode**
  - 7 types of weekly schedule and 3 programmings per day

**Other**



**Remote sensor**  
TCB-TC41LE

Install this sensor when outside air has been introduced or when overcooling and overheating are to be minimised.



**Wired remote controller for air to air heat exchanger**  
NRC-01HE

- Up to 8 units of the Air to Air Heat Exchanger can be operated using this remote controller.
- Control by 2 remote controllers is available.  
Two remote controllers can operate a single Air to Air Heat Exchanger.
- Air conditioning units may be controlled in addition to controlling the Air to Air Heat Exchanger.
- Central control allows linked ON/OFF operation of air conditioner and Air to Air Heat Exchanger.
- Central control can be set to allow standalone operation of the Air to Air Heat Exchanger.
- Switchable ventilation modes (Automatic/Air to Air/Normal)
- Switchable ventilation air volume (Extra-high/High-Low)

# Building management systems

## SMART MANAGER / SMART MANAGER WITH DATA ANALYSER

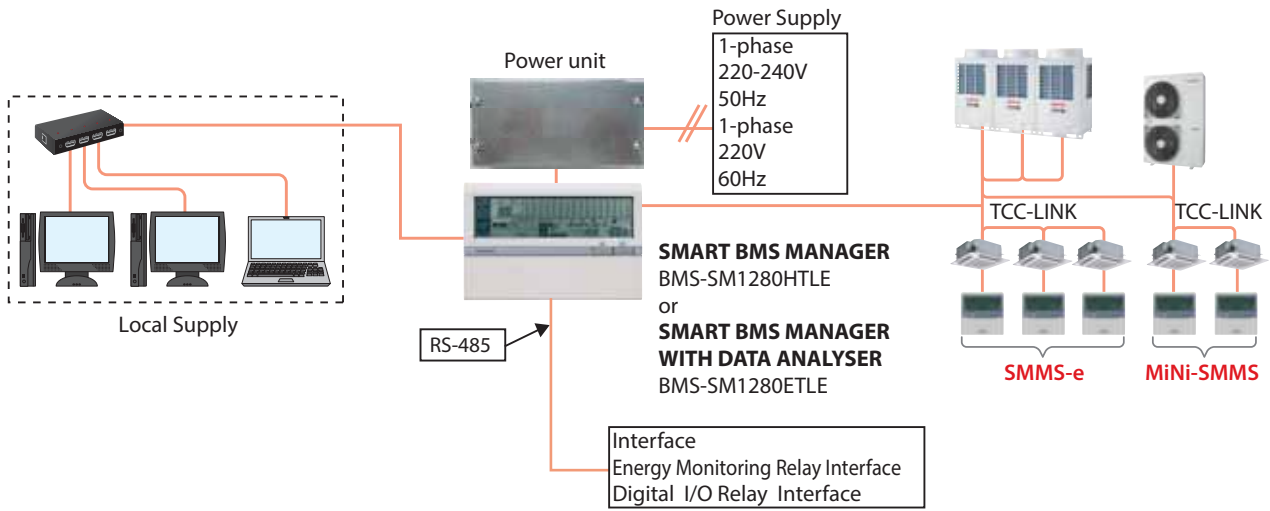

## Touch screen controller

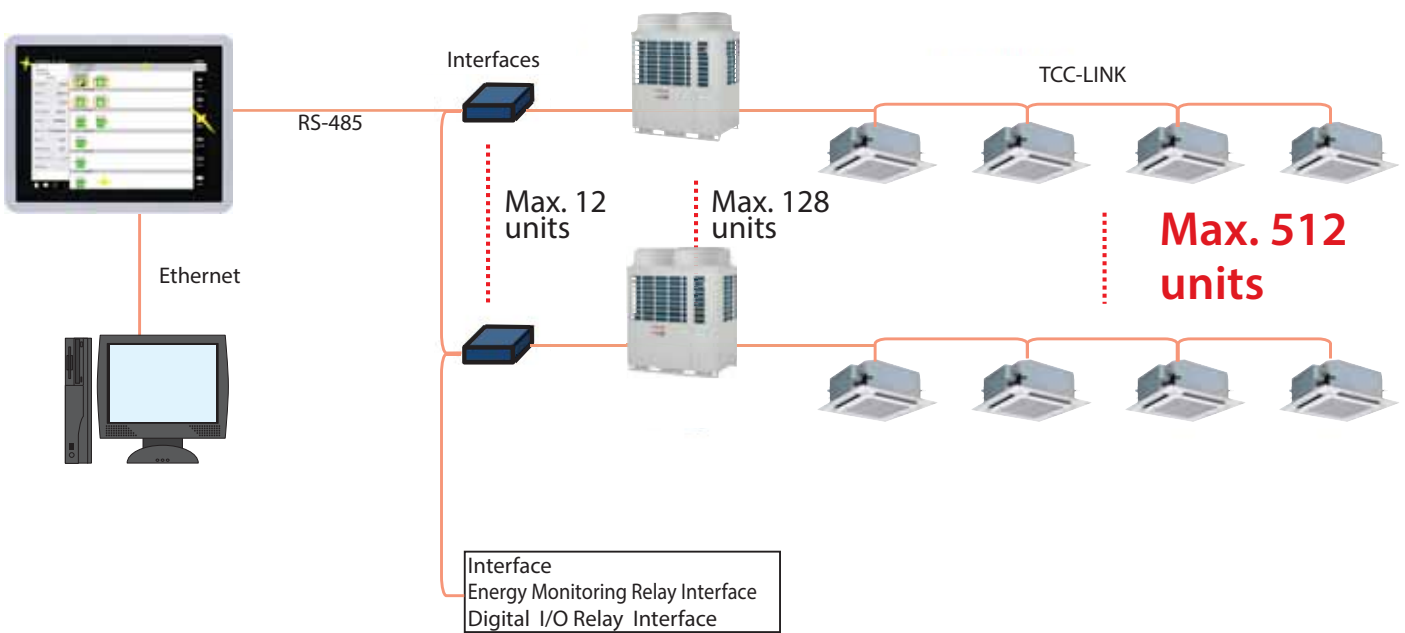

**TOUCH SCREEN CONTROLLER**  
BMS-CT5120E



**SMART BMS MANAGER**  
BMS-SM1280HTLE

**Web browser control software**

- List View available - Displays all indoor units in one screen
- Set View available - Shows basic indoor unit settings on main screen
- Advanced operation and master schedule functions available
- Advanced operation & master schedules can be set on a calendar
- Up to 4 concurrent users can be connected
- Up to 32 user accounts can be programmed with different levels of access (at least 1 must be administrator level)
- Energy monitoring and billing functions available
- Additional digital I/O device available
- Thin profile controller and separate power supply unit enables easy installation.

**SMART MANAGER WITH DATA ANALYSER**  
BMS-SM1280ETLE



**Energy monitoring display**

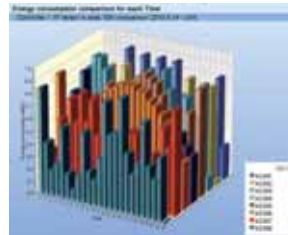

3D energy view

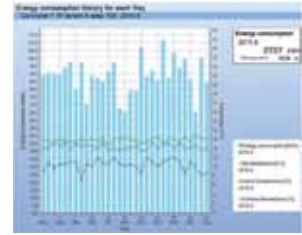

Daily energy view



**TOUCH SCREEN CONTROLLER**  
BMS-CT5120E

**• Touch screen controller**

Using the touch screen controller provides a clear display and enables easy operation.  
A maximum of 512 units / groups are controllable.

**• Energy monitoring and billing application**

Power meter interface, power meter locally supplied Energy Monitoring relay I/F (BMS-IFWH5E)

**• Power meter**

(Local Supply)  
1 kWh/pulse or 10 kWh/pulse  
(Pulse duration 50 to 1000 ms)  
(Maximum 8 power meters per interface)



**Relay Interface BMS-IFWH5E**  
For Energy Monitoring



**Relay Interface BMS-IFL5V4E**  
For TCS-NET

**Relay Interface BMS-IFDD03E**  
For Digital I/O

**FEATURES**

- Icon display
- Return back function
- Save & demand control for outdoor unit
- Ventilation unit control & monitoring
- Setting temp. range control
- Setting temp. shift

# Open network systems

## BACnet® system

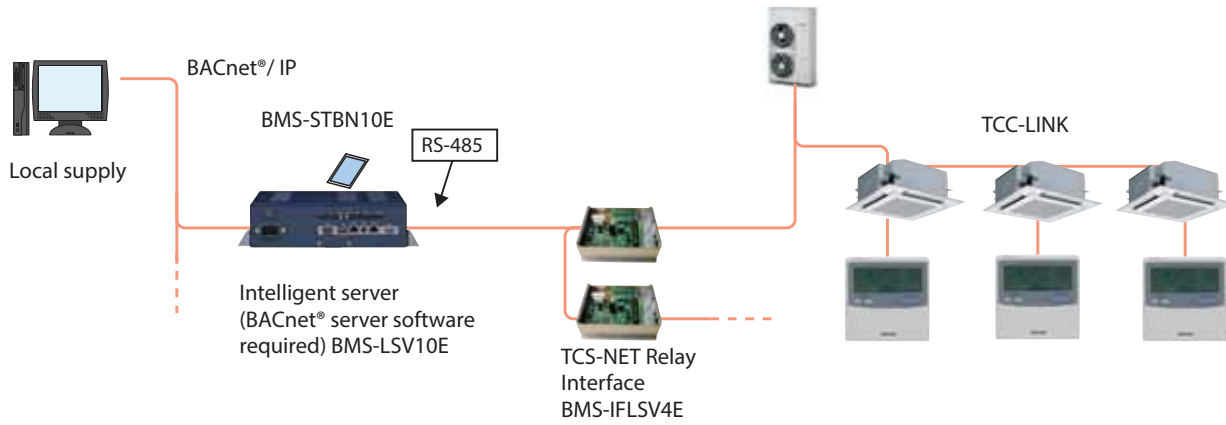

## LonWorks®

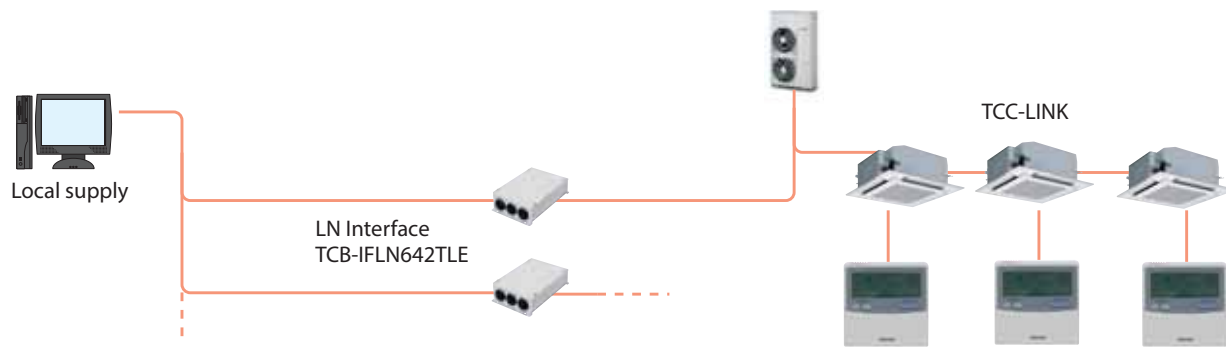

## Modbus®

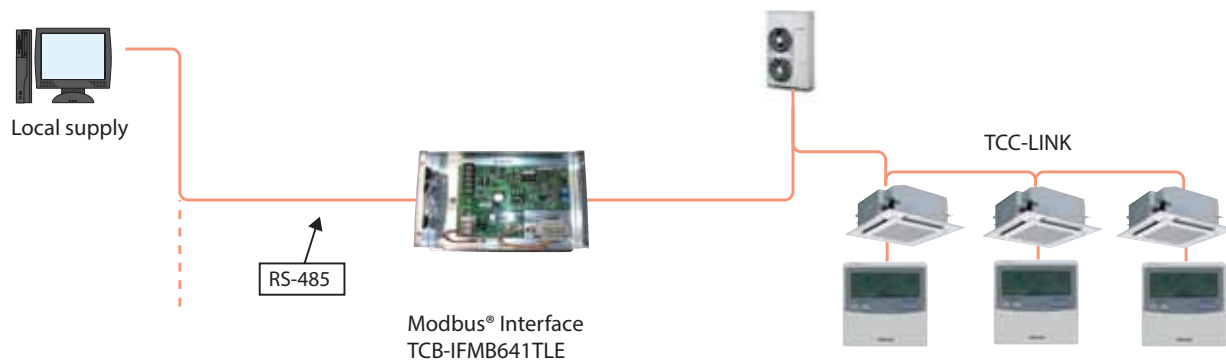



**Intelligent Server**  
BMS-LSV10E

• **BACnet®**

The BACnet® system operates in conjunction with the BACnet®. Server uses object signals to provide the following functions:

• **Control**

- ON/OFF
- Temperature setting
- Fan speed

• **Monitoring**

- ON/OFF
- Operation mode
- Temperature setting
- Room temperature
- Local remote controller : permit / prohibit



**BACnet® Server Software**  
BMS-STBN10E



**Relay Interface BMS-IFLSV4E**  
For TCS-NET



**LN Interface**  
TCB-IFLN642TLE

• **LonWorks® LN Interface**

The LonWorks® interface manages the MiNi-SMMS air conditioning system as a Lon device to communicate with the customer's Building Management System and to monitor operational status.

A maximum of 64 units / groups are controllable per interface.

• **SNVT signal**

Signals and provides the following functions:

• **Control**

- ON/OFF
- Temperature setting
- Fan speed

• **Monitoring**

- ON/OFF
- Operation mode
- Temperature setting
- Room temperature
- Local remote controller : permit / prohibit



**Modbus® Interface**  
TCB-IFMB641TLE

• **Modbus®**

The Modbus® interface manages the MiNi-SMMS air conditioning system as a Modbus® device to communicate with the customer's Building Management System.

Accessible to 64 units / groups per one TCB-IFMB641TLE, 15 TCB-IFMB641TLEs on one Modbus® Master (prepared by user).

Signals and provides the following functions:

• **Control**

- ON/OFF
- Temperature setting
- Fan speed

• **Monitoring**

- ON/OFF
- Operation mode
- Temperature setting
- Room temperature
- Local remote controller : permit / prohibit

1. LonWorks®: Registered trademark Echelon corporation.

2. BACnet®: ANSI/ASHRAE 135-2008, A data Communication Protocol for Building Automation and Control Networks.

3. Modbus® is a registered trademark of Schneider E.

# Application controls

## TCB-PCDM4E



Size: 71 × 85 (mm)

### Power peak-cut control

#### • Feature

The upper limit capacity of the outdoor unit is restricted based on the outdoor power peak selected setting.

#### • Function

Two control settings are selectable by setting SW07 on the interface P.C. board on the outdoor unit.

## TCB-PCMO4E



Size: 55.5 × 60 (mm)

### Snowfall fan control

#### • Feature

The upper limit capacity of the outdoor unit is restricted based on the outdoor power peak selected setting.

### External master ON/OFF control

#### • Feature

The outdoor unit starts or stops the system.

### Night operation (Sound reduction) control

#### • Feature

Sound level can be reduced by restricting the compressor and fan speeds.

### Operation mode selection control

#### • Feature

This control can restrict the selectable operation modes.

**TCB-PCIN4E**



Size: 73 × 79 (mm)

**Error/Operation output control**

• **Feature**

Enables external output of error and operation signals.

**Compressor operation output**

• **Feature**

Enables external signal output for each compressor that is in operation within any given outdoor unit. This feature provides a practical method for calculating total operating times for each compressor.

**Operating rate output**

• **Feature**

External output of system operating rates enables remote monitoring of operating conditions.

**TCB-IFCB-4E2**

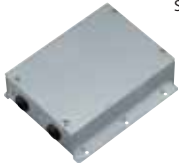

Size: 200 × 170 × 66 (mm)

**Remote location ON/OFF control box**

• **Feature**

Start and stop of the air conditioner is possible by an external signal and indication of operation/ alarm externally.

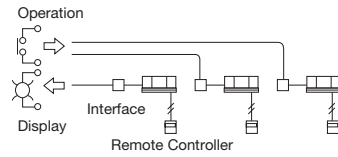

**Monitoring**

- ON/OFF status (for indoor unit)
- Alarm status (system & indoor unit stop)
- ON/OFF command
- Air conditioner can be turned ON/OFF by the external signals.
- The external ON/OFF signals will initiate the signals shown below.

# Safety precautions

## General Purpose Interface

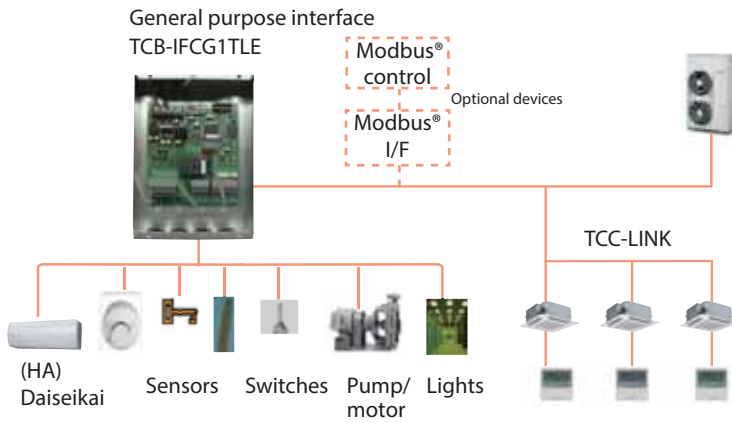

### Concept

- Controls the operation status of each indoor unit.
- ON/OFF control of peripheral equipment via the relay point of Toshiba's BMS. (1pt only)

### Standard function

Central remote controller and Building Management System devices can control ON/OFF function via digital I/O ports.

### Optional function

Control using the following channels: 4-channel relay control, 6-channel digital input, 2-channel analog voltage input and output, and 2-channel temperature measurement functions via Modbus® I/F.

## Analog Interface

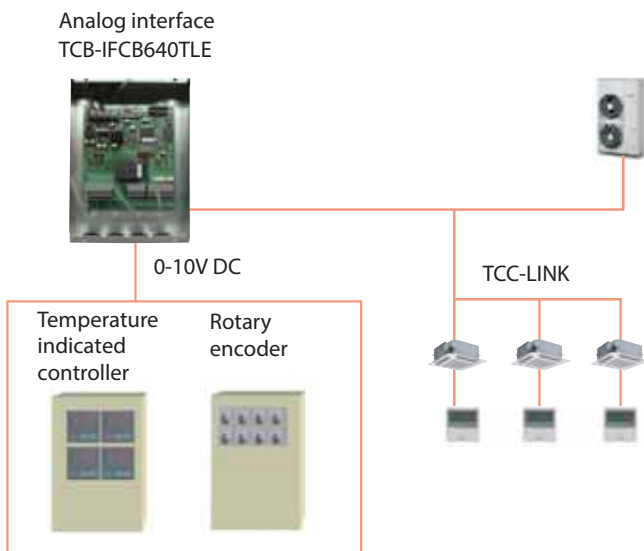

### Concept

- Provides access to 64 indoor units.
- Does not require special network knowledge.
- Can control each indoor unit on TCC-LINK, (on/off, temperature setting, airflow volume, louver position), and monitor status based on 0-10V DC voltage input.
- Enables relay control and status monitoring of general-purpose I/F TCB-IFCG1TLE.

**TOSHIBA**  
Leading Innovation >>>

# Air Conditioning for Small and Medium-size Buildings

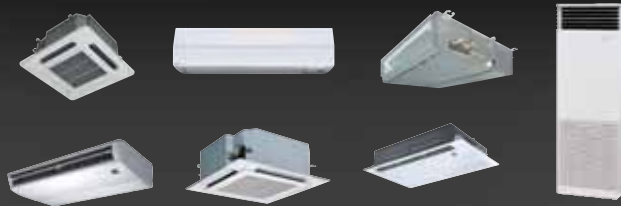

MINI-SMMS

# Defining a HIGHER standard

The all-new MiNi-SMMS air conditioner lineup lets you cool or warm as many as 12\*<sup>1</sup> rooms with a single system. Outdoor units ranging 4 to 12HP, offer best class energy savings, installation flexibility and quiet operation, plus with 13 indoor units to choose from, the MiNi-SMMS makes a perfect solution for small shops and office buildings.

\*1: 3-phase 12HP outdoor unit



**MiNi-SMMS**

**The all-new MiNi-SMMS 10 and 12HP models featuring 3-phase power supply for small and mid-size installations**

## HIGHER ENERGY SAVINGS

MiNi-SMMS achieves world-class COP of 4.40\*<sup>2</sup> and EER of 3.60\*<sup>2</sup> thanks to an integrated combination of Toshiba's more advanced twin rotary compressor, vector-controlled inverter and heat exchanger technologies.

\*2: 3-phase 6HP outdoor unit

## HIGHER COMFORT AND EASE

A single outdoor unit is powerful enough to accommodate up to 12\*<sup>1</sup> independently controlled interior units, delivering ideal quiet comfort to every room.



## **HIGHER** INSTALLATION FLEXIBILITY

MiNi-SMMS's small footprint allows for fast and easy installation. Furthermore, a maximum piping extension of 180m\*3 affords unprecedented configuration flexibility, making this unit ideal for a wide variety of applications.

\*3: 3-phase 10 and 12HP outdoor units



# HIGHER ENERGY SAVINGS

## Industry-leading energy savings

### Energy-efficient performance for greater eco-consciousness

Adopting the highly efficient DC twin-rotary compressors and advanced vector-controlled inverters realize a EER of 5.71 (under 50% partial load, 4HP). Greater operating performance is now possible when operating under a constant load.

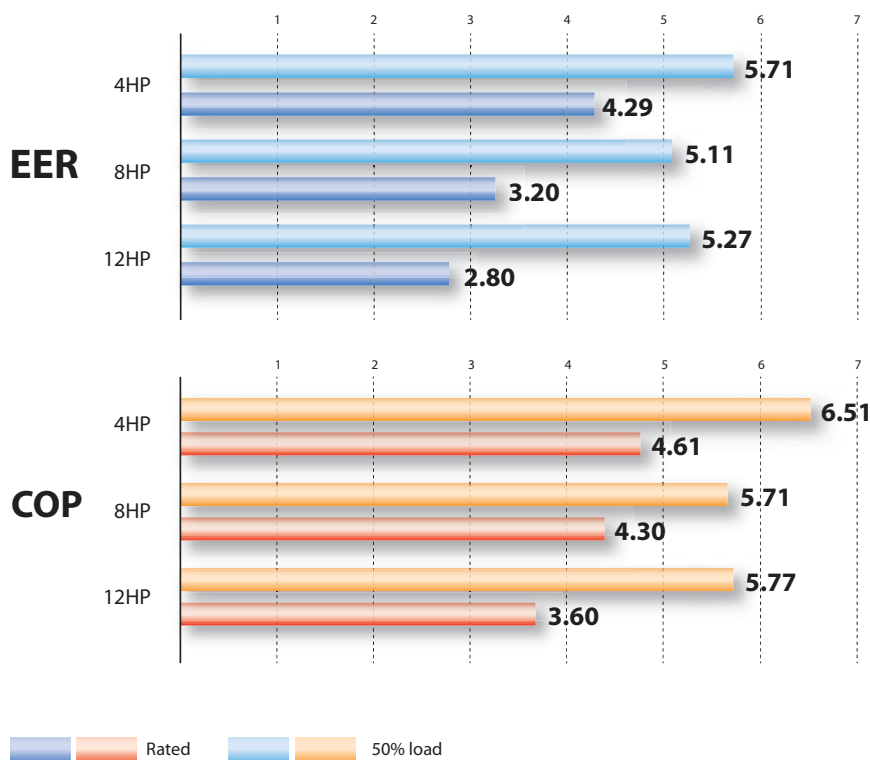

4HP: MCY-MAP0401HT/HT2D 8HP: MCY-MAP0804HT8/HT7 12HP: MCY-MHP1204HT8

\*Rated conditions

Cooling : Indoor air temperature 27°C DB / 19°C WB, Outdoor air temperature 35°C DB

Heating : Indoor air temperature 20°C DB, Outdoor air temperature 7°C DB / 6°C WB

**Toshiba's unique energy-efficient air conditioning innovations and technologies deliver high energy savings.**

**DC fan motor**

- Highly efficient DC motor
- Sine wave drive

**Heat exchanger**

High-efficiency R410A heat-transfer tube



Configuration of the finned heat-transfer tube

**Bat wing fan**

High-pressure low-volume fan



The bat wing fan realizes low sound level.

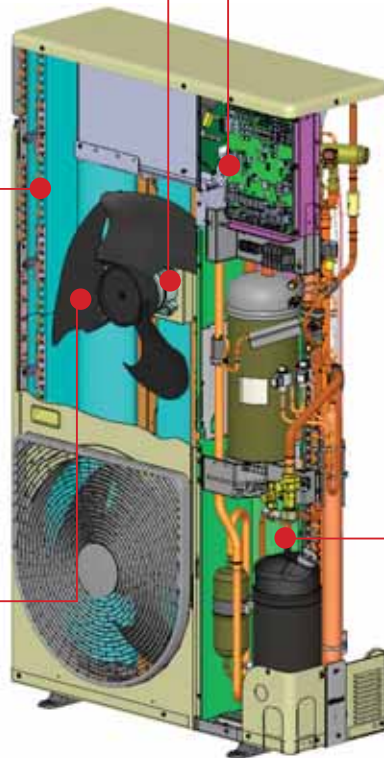

**Vector-controlled inverter**

The inverter boosts efficiency by controlling R410A and a twin-rotary DC compressor.

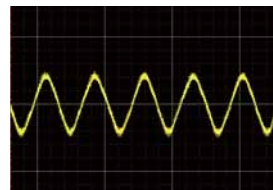

Smooth sine curve realizes higher efficiency and less noise.



Efficient circuit built-in; new PIM

Vector IPDU control changes the motor current wave to a smooth sine pattern so that noise emitted from the drive units is greatly reduced.

**Twin-rotary DC compressor**

Increased, wide range efficiency is realized.



**DC driven motor with rare-earth magnet**

- Compact
- Higher efficiency
- Higher power motor torque

**Precise manufacturing technology in the compression parts**

- Higher efficiency (in wide range)
- Higher reliability

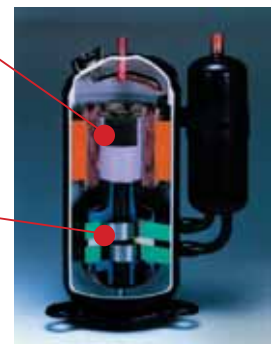



**Our MiNi-SMMS has the lowest seasonal power consumption and the highest energy conservation.**

**Why our systems make a big difference to your electricity bill even though the COP is virtually the same!**

Your electricity bill (seasonal power consumption) is highly dependent on fluctuating outside air temperature.

However, COP is calculated at only two outside temperature points, 7°C (heating rating) and 35°C (cooling rating) which is often not representative of actual conditions.

To estimate energy savings, you should factor the actual outside air temperature generation time into your seasonal power consumption.

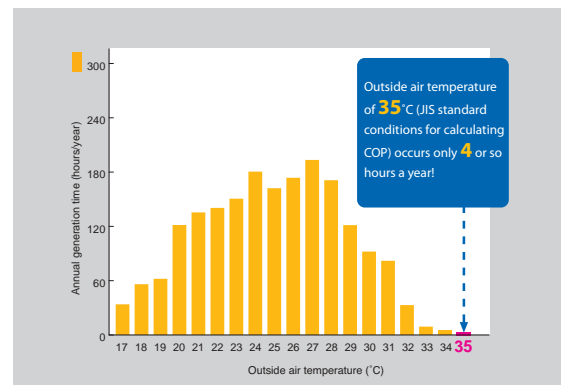

Outside air temperature conditions for calculating COP during cooling (from 8:00 to 21:00 in Tokyo)

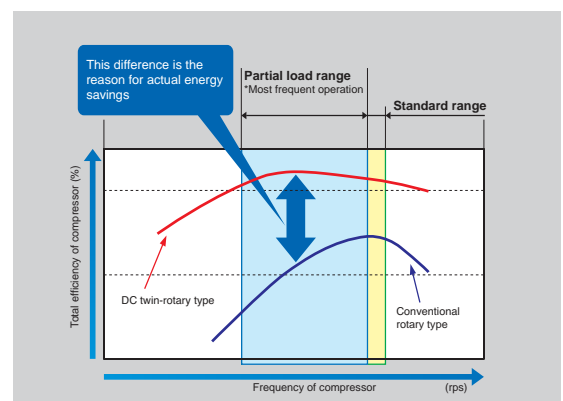

Comparison of DC twin-rotary and conventional rotary compressors



## Mechanism of improving COP

### Improves both COP and reliability

What accounts for the improvement in COP? Previous multi-system outdoor units like the SMMS required both an oil separator and a power source for the oil separator, but this system needs neither, thus improving COP.

### Oil separator unnecessary

Oil separator:  
This component separates the oil and refrigerant that are released from the compressor, and returns the oil to the compressor.

### Amount of oil released from compressor reduced



## DC twin-rotary compressor advantage

MiNi-SMMS uses twin-rotary inverter compressors that deliver a more stable, energy-efficient performance through their full range of compressor rotation when compared to scroll type compressors. Scroll compressors too can achieve high-efficiency operation, but only within a narrow range. As VRF systems require a wide range of capacity, twin-rotary compressors are the ideal choice.

# HIGHER COMFORT AND EASE

A single outdoor unit is powerful enough to accommodate up to 12\* independently controlled interior units, delivering ideal quiet comfort to every room.

\*3-phase 12HP outdoor unit

## Comfort and wide application control

The ON-OFF controller makes it easy to manage all indoor units from a single location.

ON-OFF controller  
TCB-CC163TLE2



All ON-OFF button

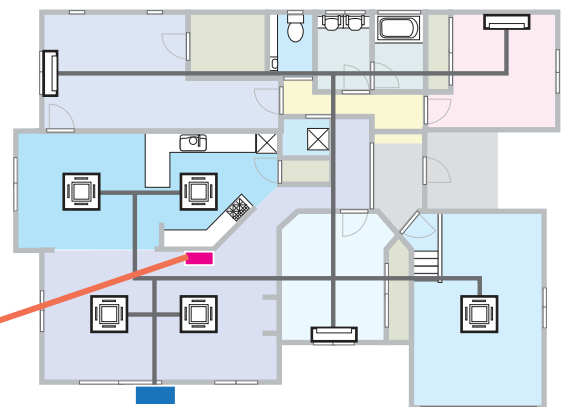

Indoor Unit Outdoor Unit

## Smart Manager for remote management

By connecting a PC to the system via Ethernet, temperatures and operation in each room can be remotely monitored and controlled. Furthermore, daily, weekly, and monthly schedules can be set for automated operation.

SMART MANAGER  
BMS-SM1280HTLE



### Mini-SMMS

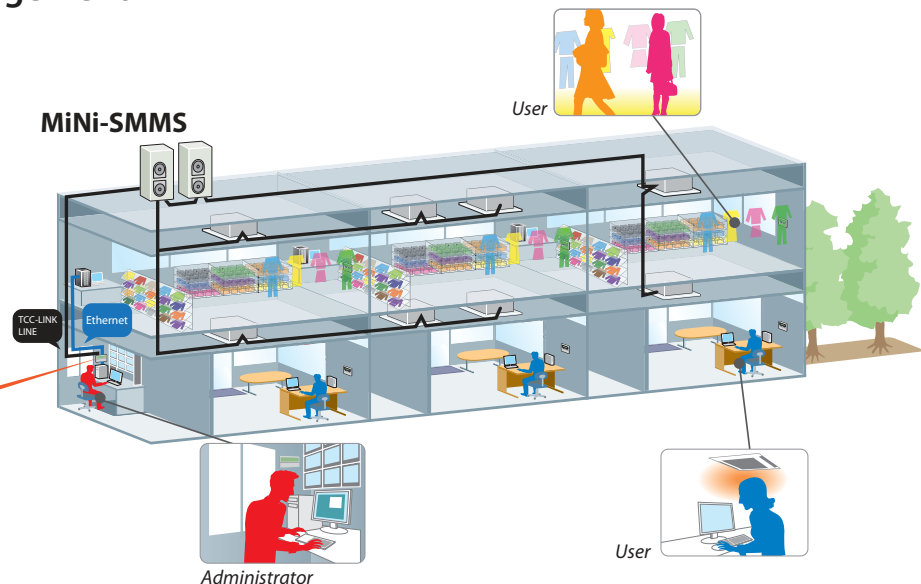



## PMV kit for quieter operation

An optional PMV kit allows quieter placement by efficiently reducing the sound made by the refrigerant in the piping.

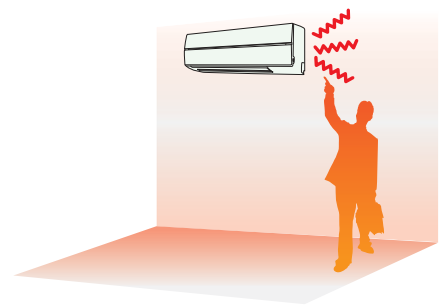
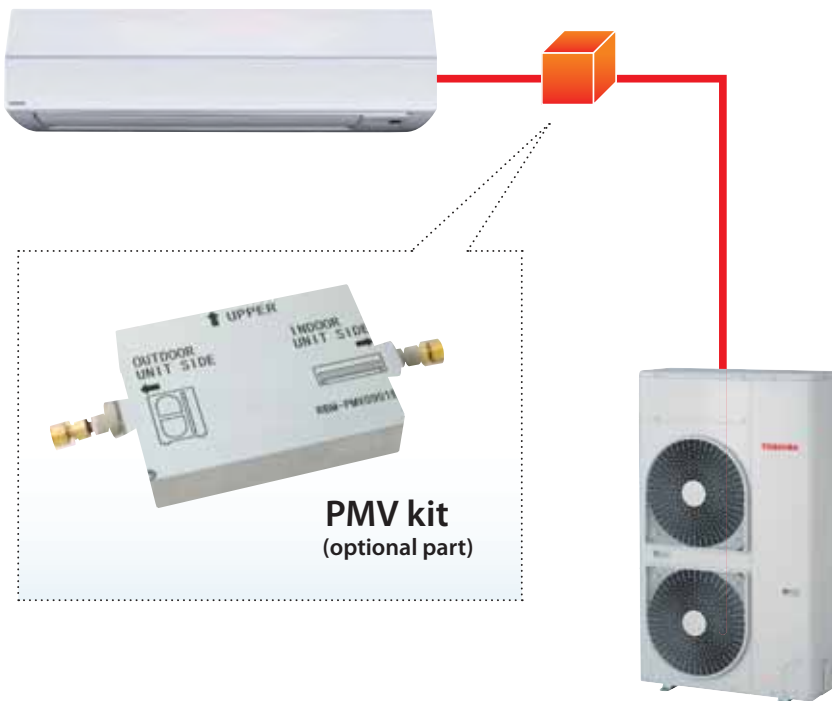

The PMV function is normally inside the indoor unit, and is the cause of most of the noise from the indoor unit.

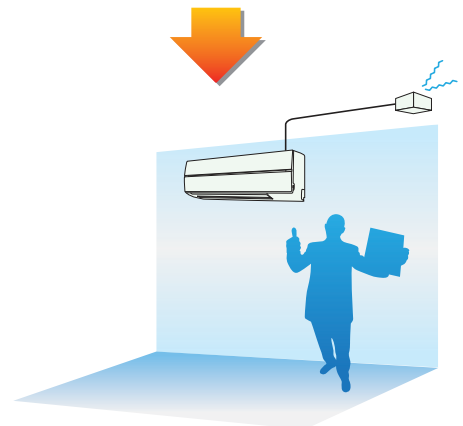

If the PMV function is removed from the indoor unit, noise can be significantly reduced.



## Bat wing fan

Fan blade design plays a significant part reducing noise and vibration. Anti-eddy projections and reverse-arc shaped wings reduce air resistance resulting in low operating noise of the outdoor unit.

### 1-phase outdoor unit

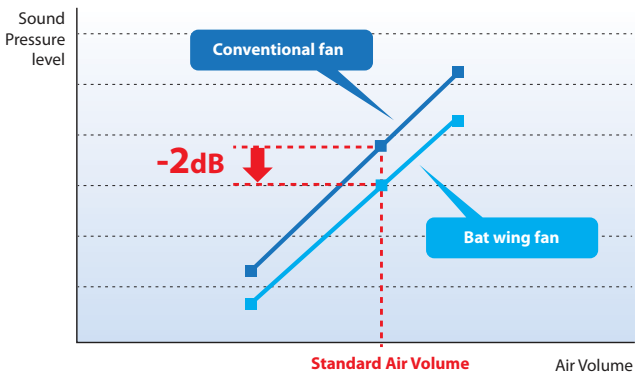

**At same air volume, sound is reduced by 2 dB.**

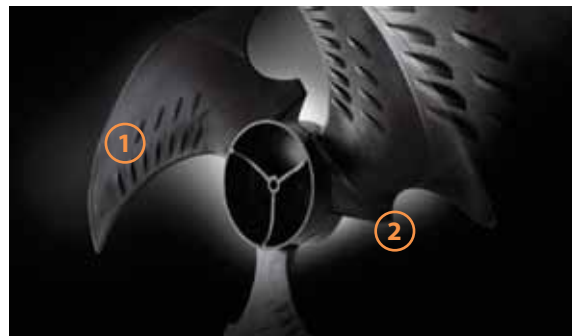

- ① **Anti-eddy projections**  
Minimizes the generation of large eddies.
- ② **Reverse-arc-shaped wing**  
Reduces rear turbulence due to less pressure loss.





## Night operation (sound reduction) control

(with optional PC Board (TCB-PCMO4E) and locally supplied timer/switch)

The unit also comes with a night-time low-noise mode, which reduces operating noise at the programmed activation time. (Timer or switch to be locally obtained.)

### 1-phase outdoor unit

Operation control		Normal	Night
<b>4HP</b>	Cooling	<b>49</b> dB(A)	<b>46</b> dB(A)
<b>5HP</b>	Cooling	<b>50</b> dB(A)	<b>46</b> dB(A)
<b>6HP</b>	Cooling	<b>51</b> dB(A)	<b>47</b> dB(A)

### 3-phase outdoor unit

Operation control		Normal	Night
<b>6HP</b>	Cooling	<b>58</b> dB(A)	<b>50</b> dB(A)
<b>8HP</b>	Cooling	<b>58</b> dB(A)	<b>50</b> dB(A)
<b>10HP</b>	Cooling	<b>58</b> dB(A)	<b>50</b> dB(A)
<b>12HP</b>	Cooling	<b>61</b> dB(A)	<b>50</b> dB(A)

\*Sound pressure level: dB(A)





# HIGHER INSTALLATION FLEXIBILITY

## Small footprint

The outdoor unit has a small physical footprint of only 0.29m<sup>2</sup> and 0.39m<sup>2</sup>, taking up as little space outside as possible.

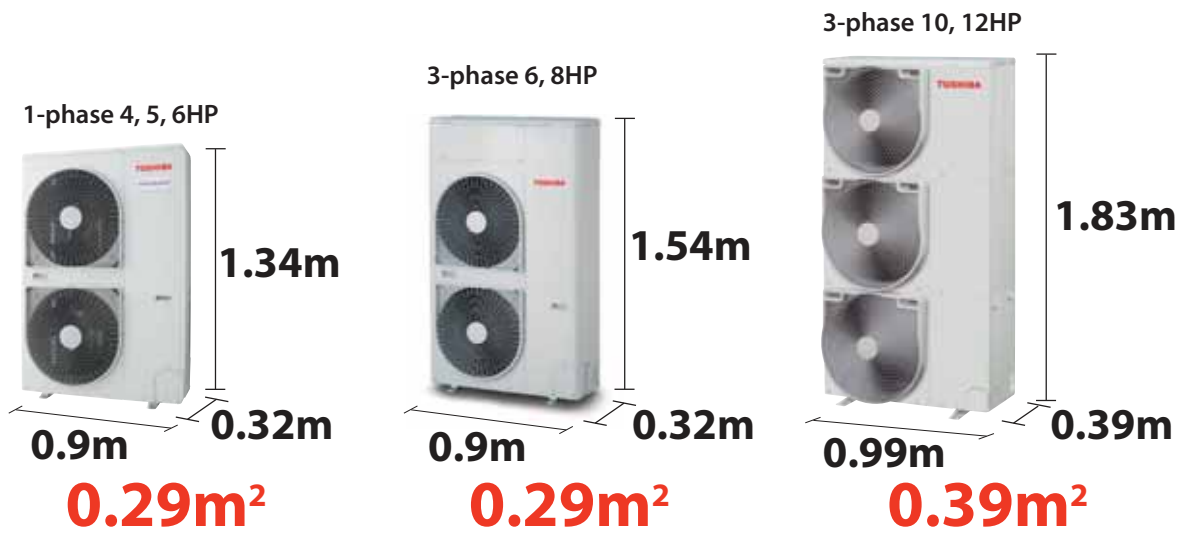

## Mini-SMMS is suitable for balconies

The outdoor unit is compact and expels exhaust air to the side, so it can be installed even in limited spaces as shown.

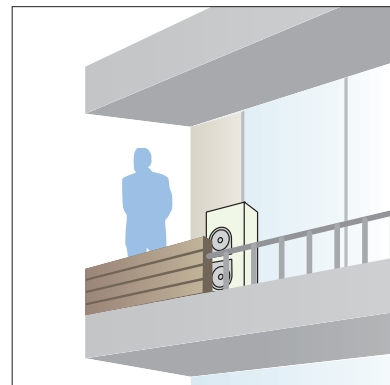

## Shortest route design by free branching

Combination of line and header branching is highly flexible, allowing the shortest route possible thereby saving on installation time and costs.

Header branching after header branching is only available with Toshiba systems.

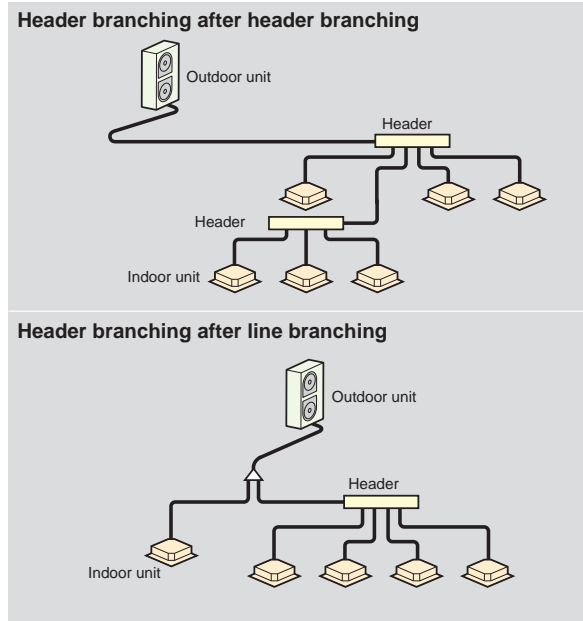

## Maximum piping length with PMV kit

Extended refrigerant piping possibilities are possible even with the optional PMV kit installed.

3-phase 6 and 8HP outdoor units have a maximum pipe extension of 100m, regardless of PMV kits used.

3-phase 10 and 12HP outdoor units have a maximum pipe extension of 180m, and 150m when equipped with PMV kits.

On 1-phase outdoor units, piping lengths will differ when PMV kits are used, as shown below.

### 1-phase outdoor unit

#### When PMV kit is not used

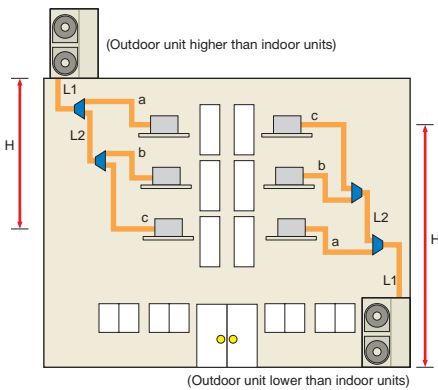

	Piping length	
Not used	Maximum pipe extension (Liquid pipe, real length)	Used
180	Piping section: L1+L2+a+b+c	150
125	Farthest piping length (equivalent length)	80
	Piping section: L1+L2+c	
Height difference		
30	Height between indoor and outdoor units (Outdoor unit higher than indoor units)	30
	Piping section: H	
20	Height between indoor and outdoor units (Outdoor unit lower than indoor units)	20
	Piping section: H	

#### When PMV kit is used

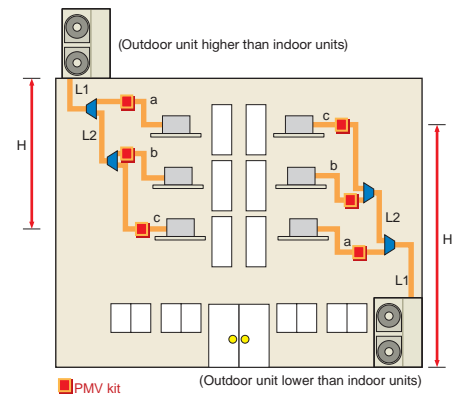

PMV kit



### Maximum piping length (3-phase outdoor units)

With a maximum piping length of up to 120m\*, the outdoor unit can be placed far away and out of sight.

\*: 3-phase 10 and 12HP outdoor units

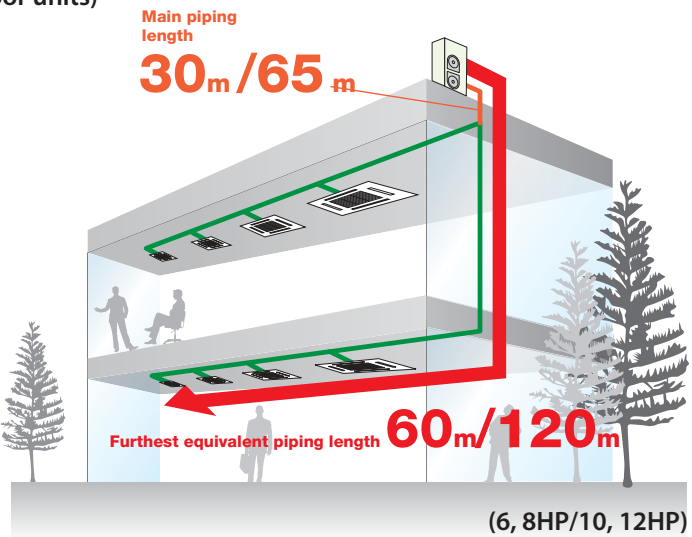

### Maximum height difference (3-phase outdoor units)

A maximum height difference of 15m means a single unit can supply indoor units on two or even three floors.

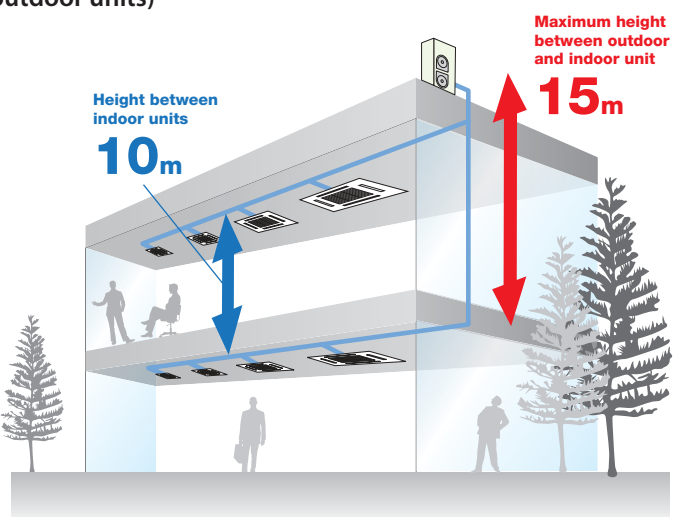

# More Attractive Features

## Reducing peak power consumption levels (optional)

An optional circuit board (TCB-PCDM4E) can be used to limit operation to specified setting ranges (Standard and Extended modes), controlled by the demand signal status. System operation is confined to a range that does not exceed thresholds.

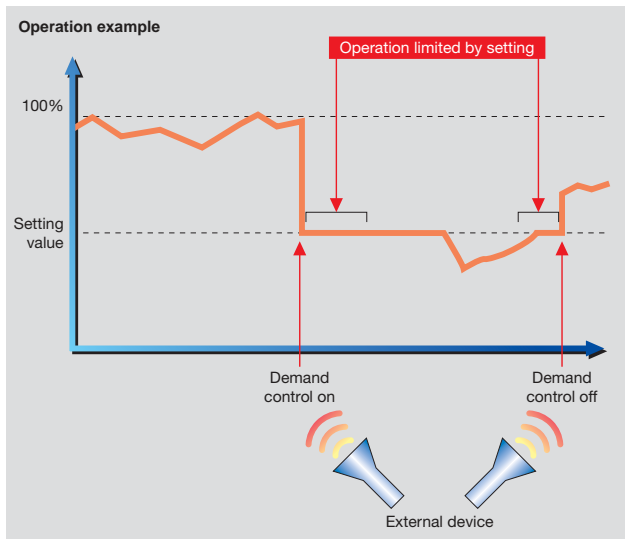

Mode	Pattern	Selectable Capacity
Standad (2-step)	A	100%(Normal) / 0%(Stop)
	B	100%(Normal) / Up to 60%
Extended (4-step)	A	100%(Normal) / Up to 80% / Up to 60% / 0%(Stop)
	B	100%(Normal) / Up to 85% / Up to 75% / Up to 60%

Note: The above limitations do not apply at startup after heating operation has been turned off, during defrosting, and when heating operation is starting after defrosting finishes.

## Outdoor units line-up

### 1-phase model

				
Capacity		4HP	5HP	6HP
Model Name	50 Hz (MCY-)	MHP0404HT-SG	MHP0504HT-SG	MHP0604HT-SG
Cooling capacity*	(kW)	12.1	14.0	15.5
Power supply		1-phase 2 wires 50Hz 220 - 240 V		

### 3-phase model

					
Capacity		6HP	8HP	10HP	12HP
Model Name	50 Hz (MCY-)	MAP0604HT8	MAP0804HT8	MHP1004HT8	MHP1204HT8
Cooling capacity*	(kW)	15.5	22.4	28.0	33.5
Power supply		3-phase 4 wires 50Hz 380V-415V		3-phase 4 wires 50Hz 380V-415V	

\*Rated conditions

Cooling : Indoor air temperature 27°C DB / 19°C WB, Outdoor air temperature 35°C DB

Heating : Indoor air temperature 20°C DB, Outdoor air temperature 7°C DB / 6°C WB

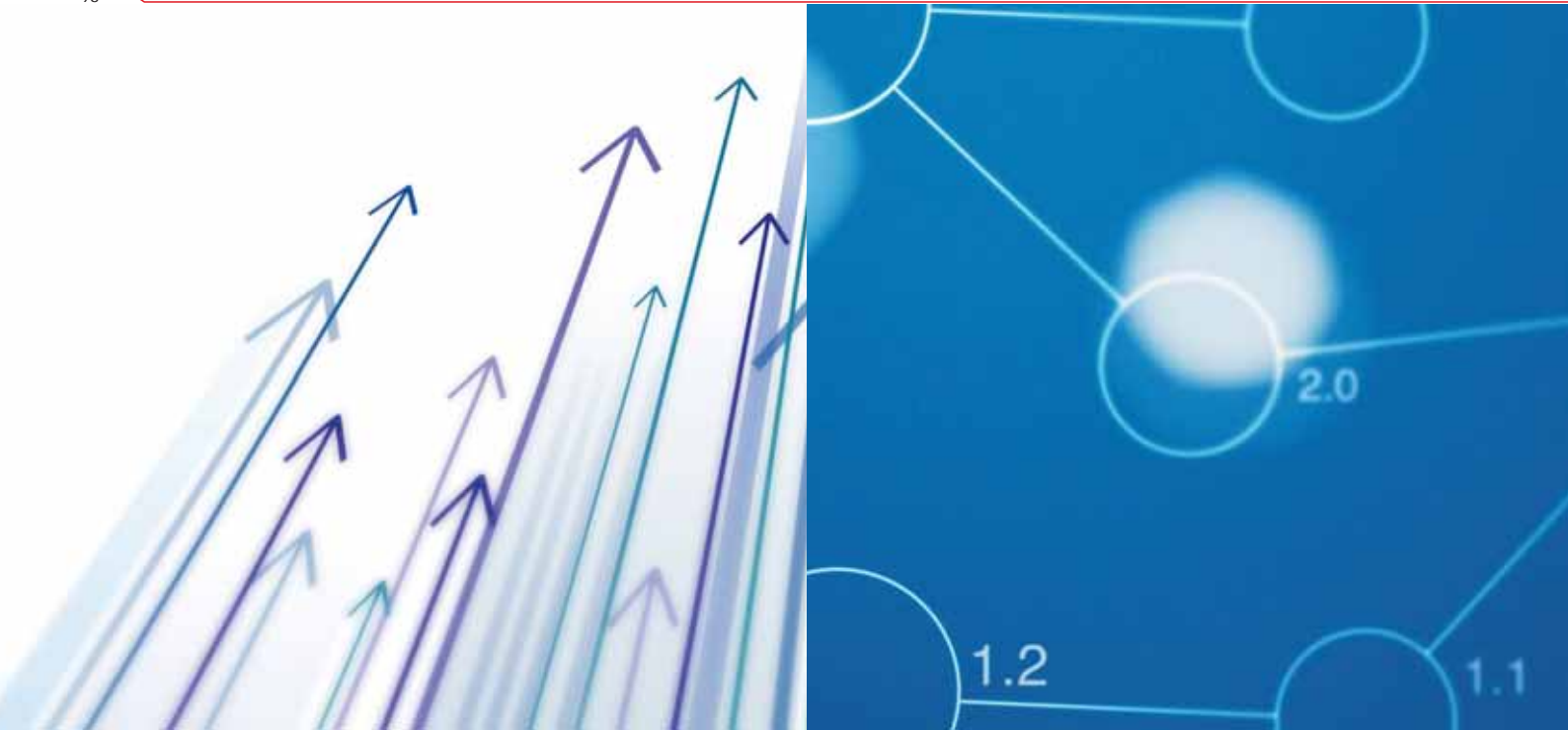

## Optimal refrigerant control

When a multiple number of indoor units are connected, an insufficient or excess amount of refrigerant may be supplied to indoor units depending on the difference in length of the connection pipe from the outdoor unit.

This is because pressure loss and heat leaks occur as the refrigerant travels through the pipes, resulting in incorrect amounts of refrigerant being supplied to the indoor units.

Optimal refrigerant control uses a multiple number of refrigerant sensors to detect the air-conditioning status of each indoor unit and precisely controls the capacity (amount of refrigerant) to eliminate variations.

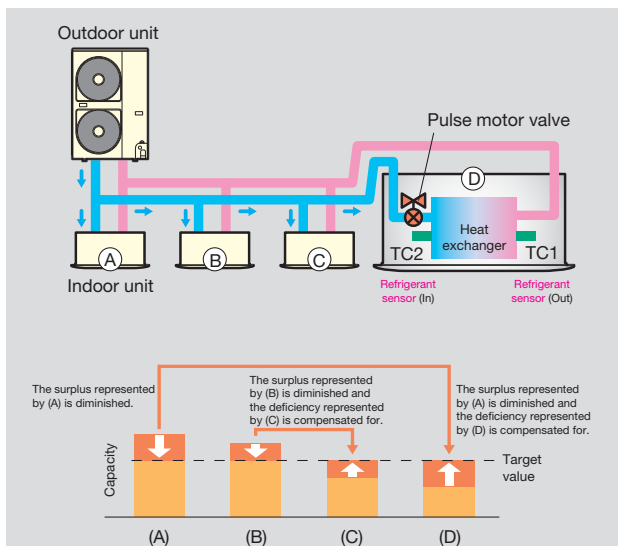

**Branching joints and headers**

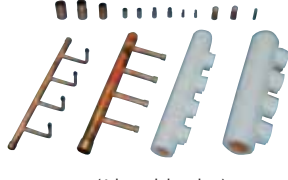
	Y-shape branching joint		Branch headers	
Appearance				
Model name (RBM-)	BY55E (Below 6.4HP)	BY105E (6.4HP or more)	HY1043E (Max. 4 branches)	HY1083E (Max. 8 branches)

**PMV kit**

	PMV kit	
Appearance		
Model name (RBM-)	PMV0362E	PMV0902E
Indoor unit capacity type	007/009/012 type	015/018/024 type

## Outdoor unit specifications

1-phase model

**Technical specifications**

Equivalent HP		4HP	5HP	6HP		
Model name		MCY-MHP0404HT-SG	MCY-MHP0504HT-SG	MCY-MHP0604HT-SG		
Outdoor unit type		Inverter unit				
Power supply		1-phase 50Hz 220 – 240 V / 1-phase 60Hz 220V				
Cooling *1	Capacity 100%	(kW)	12.1	14.0	15.5	
	Power consumption	(kW)	2.88	3.50	4.35	
	EER (Energy Efficiency Ratio)	Capacity 100%		4.20	4.00	3.56
		Capacity 80%		4.92	4.74	4.24
		Capacity 50%		6.22	6.25	5.73
Heating *1	Capacity 100%	(kW)	12.5	16.0	18.0	
	Power consumption	(kW)	2.73	3.81	4.50	
	COP (Coefficient of Performance)	Capacity 100%		4.58	4.20	4.00
		Capacity 80%		4.92	4.67	4.52
		Capacity 50%		5.77	5.88	5.88
External dimensions (Height / Width / Depth)		(mm)	1235 / 990 / 390			
Total weight		(kg)	115			
Compressor	Motor output	(kW)	3.75	3.75	3.75	
Fan unit	Motor output	(kW)	0.1 + 0.1			
	Air volume	(m <sup>3</sup> /h)	6030	6210	6410	
Refrigerant piping Specifications	Connecting port dia.	Gas side (OD)	(mm)	15.9		
		Liquid side (OD)	(mm)	9.5		
	Max. pipe extension (Liquid pipe, real length)	(m)	90 (75 *2)			
	Max. pipe length (Real length)	(m)	50 (40 *2)			
	Max. pipe length (Equivalent length)	(m)	60 (50 *2)			
	Max. height between indoor and outdoor units	(m)	Outdoor unit higher than indoor unit: 15			
			Outdoor unit lower than indoor unit: 15			
Max. no. of connected indoor units			6	6	6	
Sound pressure level (Cooling/Heating) *3		(dB(A))	50/52	51/54	52/55	
NEA Green ticks			3	3	2	

\*1 Rated conditions Cooling : Indoor air temperature 27°C DB / 19°C WB, Outdoor air temperature 35°C DB  
 Heating : Indoor air temperature 20°C DB, Outdoor air temperature 7°C DB / 6°C WB  
 The standard pipe means that equivalent piping length of 7.5 m and standard 0 m piping height difference.

\*2 When PMV kit is used

\*3 Sound pressure levels measured in an anechoic chamber in accordance with JIS B 8616.

## 3-phase model

## Technical specifications

Equivalent HP		6HP	8HP	10HP	12HP		
Model name	50Hz (MCY-)	MAP0604HT8	MAP0804HT8	MHP1004HT8	MHP1204HT8		
Outdoor unit type		Inverter unit					
Power supply		3-phase 4 wires 50Hz 380 - 415V		3-phase 4 wires 50Hz 380 - 415V			
Cooling <sup>*1</sup>	Capacity 100%	(kW)	15.5	22.4	28.0	33.5	
	Power consumption	(kW)	4.31	7.00	9.34	11.98	
	Efficiency (iKw/RT)	Capacity 100%		0.98	1.10	1.17	1.26
		Capacity 80%		0.77	0.87	0.96	1.01
		Capacity 50%		0.61	0.69	0.68	0.67
	EER (Energy Efficiency Ratio)	Capacity 100%		3.60	3.20	3.00	2.80
		Capacity 80%		4.56	4.05	3.67	3.49
Capacity 50%			5.74	5.11	5.20	5.27	
External dimensions (Height / Width / Depth)		(mm)	1540 / 900 / 320		1825 / 990 / 390		
Total weight (kg)			123	162	164		
Compressor	Motor output	(kW)	3.75		5.60		
Fan unit	Motor output	(kW)	0.1 +0.1		0.1 +0.1 +0.1		
	Air volume	(m <sup>3</sup> /h)	7860		11100	12000	
Refrigerant piping Specifications	Connecting port dia.	Gas side (OD)	(mm)	19.1	22.2	22.2	25.4
		Liquid side (OD)	(mm)	9.5		12.7	
	Max. pipe extension (Liquid pipe, real length)		(m)	100 (100) <sup>*2</sup>		180 (150) <sup>*2</sup>	
	Max. pipe length (Real length)		(m)	50 (50) <sup>*2</sup>		100 (65) <sup>*2</sup>	
	Max. pipe length (Equivalent length)		(m)	60 (60) <sup>*2</sup>		120 (80) <sup>*2</sup>	
	Max. height between indoor and outdoor units		(m)	Outdoor unit higher than indoor unit: 15			
			Outdoor unit lower than indoor unit: 15				
Max. no. of connected indoor units			8	8	10	12	
Sound pressure level (Cooling) <sup>*3</sup>		(dB(A))	58	58	58	61	

\*1 Rated conditions Cooling : Indoor air temperature 27°C DB / 19°C WB, Outdoor air temperature 35°C DB

\*2 When PMV kit is used

\*3 Sound pressure levels measured in an anechoic chamber

※ Anti-Corrosion protection model : MCY-MAP\*\*\*\*HT8ZG, MCY-MAP\*\*\*\*HT7ZG, except 10HP, 12HP.



**3-phase model :**  
**MCY-MAP0604HT8, MAP0804HT8 (50Hz)**

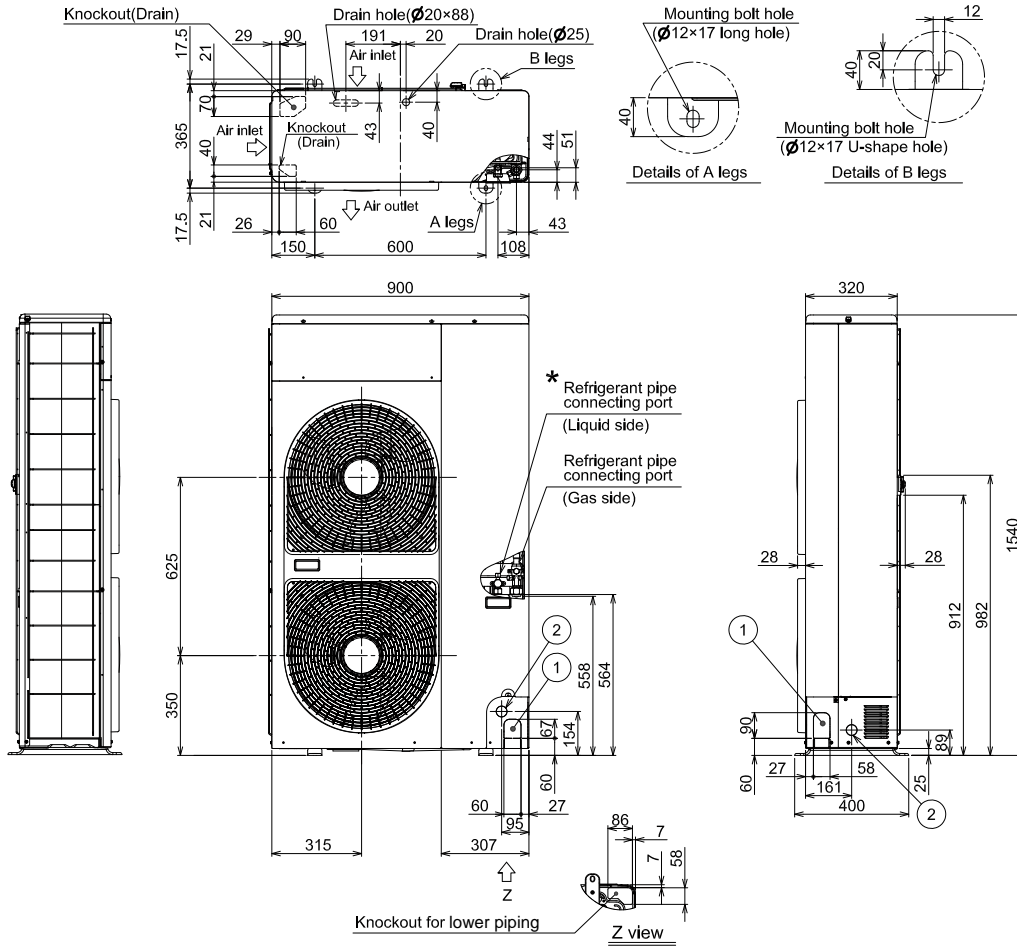

	Name	Note
①	Refrigerant piping hole Indoor/Outdoor Unit connecting wire inlet hole	—
②	Power supply inlet hole	Ø38 Knockout hole

**Diameter of refrigerant pipe**

Model name	Gas side	Liquid side
MCY-MAP0604HT8/HT7	Ø19.1	Ø9.5
MCY-MAP0804HT8/HT7	Ø19.1	Ø9.5

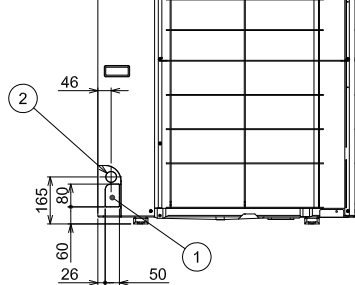

(Unit:mm)



## Installation and the use of refrigerants not specified by Toshiba Carrier Corporation

Toshiba refrigeration and air-conditioning units are designed and manufactured on the assumption that the product is used with a specific refrigerant suitable for each unit.

We have recently seen some cases where the type of refrigerant used is different from the one originally installed in the product. Such actions may cause mechanical defects, malfunctions, failures and in some cases result in a serious safety issue. Therefore do not install any refrigerant other than the one specified by Toshiba Carrier Corporation for its respective products.

The type of the refrigerant used for each of our products is shown in the accompanying owners manual, or on the product label attached on the product itself.

Toshiba Carrier Corporation shall not assume any liability for failures, malfunctions or safety in its products if the refrigerant used is different from the one specified.



## SAFETY PRECAUTIONS

### For operation:

- Before use, read through the operating instructions to ensure proper use.

### Concerning the purpose for which the air conditioners are to be used

- The air conditioners presented in this catalogue are air conditioning/heating units to be used solely by general consumers.
  - Do not use these air conditioners for special applications such as for the storage of food items, animals, plants, precision machines or works of art. Doing so may degrade the quality of the items.
  - Do not use these air conditioners for air-conditioning applications in vehicles or ships. Doing so may cause water and/or power leakages.

## Precautions for using air conditioners

### Concerning the automatic defrosting unit

When the outdoor air temperature drops, frost may form on the heat exchanger of the outdoor unit. In such cases, the automatic defrosting unit will be activated, and it will take 5 to 8 minutes for the heating operation to be restored.

### Concerning the air conditioner's operating conditions and their selection

(1) Avoid using the air conditioner in the following locations.

- Locations with acidic or alkaline atmospheres (locations at which highly acidic or alkaline air is directly drawn in, such as in hot springs areas from which sulfur gases are given off, or where chemicals, vinegar, exhaust air from burners, etc., are given off) The heat exchangers and other parts may become corroded.
- Locations with atmospheres filled with coolant or other machine oil or steam exhaust (such as at food preparation factories or machine plants). The heat exchangers may corrode; frost may form as a result of heat exchanger malfunction; air conditioner operating performance may be compromised or condensation may form as a result of clogged filters; plastic parts may incur damage; heat-insulation materials may become separated, etc.

(2) Before using an air conditioner in any of the following locations, consult with your dealer or a qualified contractor.

- Locations where vapors from edible oils are given off (such as in bakeries or kitchens and restaurants that use edible oils) ...The air conditioner's operating performance may be compromised or condensation may form as a result of clogged filters, and the plastic parts may incur damage. In line with the prevailing conditions, take countermeasures such as tailoring the installation conditions in accordance with the conditions, using air conditioners designed for kitchens or oil guard filters, etc.
- Locations with disinfectant-induced chlorine atmospheres (water tanks, etc.) The metal parts in the heat exchangers, motors, etc., may become corroded.
- Locations with high salinity (coastal areas, etc.) Corrosion may occur so use outdoor units specifically designed to withstand exposure to salt.

- Locations where power is supplied from independent power generators. The power line frequency and/or voltage may fluctuate, possibly causing the air conditioner to malfunction.
- Locations where high frequencies or electrical noise is generated (from high-frequency welders used for vinyl welding and processing, high-frequency therapeutic devices used for thermotherapy, etc.) The electronic components may be adversely affected, possibly causing the air conditioner to malfunction.
- Locations where electronic equipment is installed. Electrical noise may adversely affect the operation of the electronic equipment.

(3) Concerning use in locations with high ceilings

- In locations with high ceilings, use of circulators for improving the temperature distribution during heating is recommended.

(4) Concerning use in high-humidity environments

- When the ceiling-recessed type of indoor unit is installed in a location, such as those described below, and it is very hot and humid inside the ceiling, condensation may form on the external surfaces of the indoor unit and drip down. In such cases, add external heat-insulating materials.
  - Locations such as food preparation sites in which the areas above the ceilings are hot and humid
  - Locations in which outside air is drawn in and routed above the ceiling
  - Above ceilings with a slate roof or tiled roof overhead

(5) Even when an air conditioner is shut down, it will still consume a small amount of power to protect the unit. If the air conditioner will not be used for a prolonged period, turn OFF the main switch (ground fault circuit breaker). However, before the unit is to be used again, turn ON the main switch (ground fault circuit breaker) for at least 12 hours in order to prevent trouble.

# TOSHIBA

Leading Innovation >>>



ISO9001  
QUALITY MANAGEMENT SYSTEM

ISO14001  
ENVIRONMENTAL MANAGEMENT SYSTEM

TIS18001  
TOSHIBA INTEGRATED SYSTEM

O H S A S  
OCCUPATIONAL SAFETY AND HEALTH



Notice : Toshiba is committed to continuously improving its products to ensure the highest quality and reliability standards, and to meet local regulations and market requirements. All features and specifications are subject to change without prior notice.